

Operating Instructions

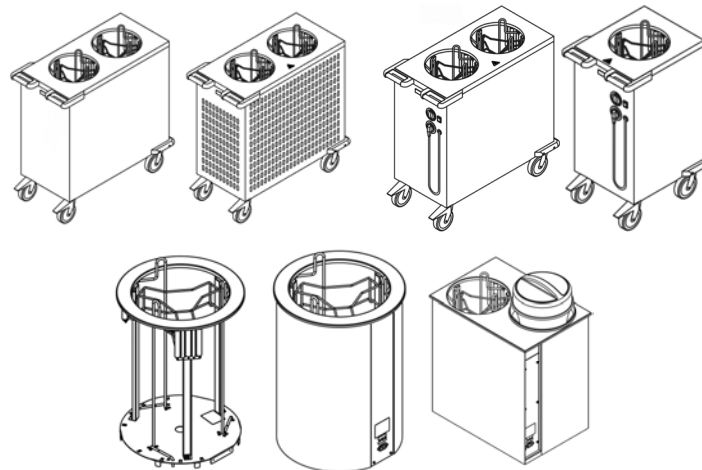

Plate dispenser

TE-2/V19-26 | TE-2/V27-33 | TE-2/VK19-26 | TEH-1/V19-26 |
TEH-1/V27-33 | TEH-2/V19-26 | TEH-2/V27-33 | TEUH-1/VS19-26
| TEUH-2/VS19-26 | TEUH-2/VS27-33 | TEUH-2/VC19-26 |
EBR/V19-26 | EBR/V27-33 | EBRH/V19-26 | EBRH/V27-33 |
EBRH-2/V19-26

1 Introduction

1.1 Appliance Information

Appliance designation	Plate dispenser
Appliance type/ -s	TE-2/V19-26 TE-2/V27-33 TE-2/VK19-26 TEH-1/V19-26 TEH-1/V27-33 TEH-2/V19-26 TEH-2/V27-33 TEUH-1/VS19-26 TEUH-2/VS19-26 TEUH-2/VS27-33 TEUH-2/VC19-26 EBR/V19-26 EBR/V27-33 EBRH/V19-26 EBRH/V27-33 EBRH-2/V19-26
Year of manufacture	2014
Manufacturer	HUPFER® Metallwerke GmbH & Co. KG Dieselstraße 20 48653 Coesfeld P.O. Box 1463 D-48634 Coesfeld ☎ +49 2541 805-0 📠 +49 2541 805-111 www.hupfer.de info@hupfer.de

Read these operating instructions carefully before the first operation of the appliance.

Ensure that sources of danger and possible faulty operations have been pointed out to the operating staff.

Subject to modifications

The products covered by these operating instructions have been developed taking into consideration the requirements of the market and the latest technology. HUPFER® reserves the right to modify the products and appertaining technical documentation in so far as the modifications are in the name of technological progress. The data and weights as well as the description of performance and functions assured in the order confirmation as binding are always decisive.

This manual is a translation of the original edition.

Manual edition

4330000_A6

1.2 Table of Contents

1	Introduction	2
1.1	Appliance Information	2
1.2	Table of Contents	3
1.3	List of Abbreviations	5
1.4	Definitions of Terms	6
1.5	Orientation Guide	7
1.6	Notes on Use of Manual	8
1.6.1	Notes on the Manual Structure	8
1.6.2	Notes and their Illustrations used in the Chapters	8
2	Safety Instructions	9
2.1	Introduction	9
2.2	Warning Symbols Used	9
2.3	Safety Instructions for Appliance Safety	9
2.3.1	Safety instructions for all appliances	9
2.3.2	Additional safety instructions for heated appliances	10
2.4	Safety Instructions for Cleaning and Care	11
2.5	Safety Instructions for Troubleshooting	11
2.6	Notes on Specific Hazards	11
3	Description and Technical Data	12
3.1	Performance Description	12
3.2	Intended Use	12
3.3	Improper Use	12
3.4	Appliance Description	13
3.4.1	View of the appliance - Plate dispenser	13
3.4.2	View of the appliance - Built-in plate dispenser	13
3.4.3	Appliance description	14
3.4.4	Optional accessories	14
3.5	Technical Data	15
3.6	Rating Plate	19
4	Transport, Assembly, Putting into Operation and Decommissioning	20
4.1	Transport	20
4.2	Assembly (Built-in appliances only)	20
4.2.1	Unheated appliances (EBR/V19-26 EBR/V27-33)	20
4.2.2	Heated appliances (EBRH/V19-26 EBRH/V27-33 EBRH-2/19-26)	22
4.3	Putting into Operation	26
4.4	Storage and Recycling	26
5	Operation	27
5.1	Arrangement and Function of the Operating Elements	27
5.2	Plate Dispenser Adjustment	27
5.2.1	Crockery guide adjustment	28

5.2.2	Spring adjustment	29
5.2.3	Calculating the plate dispenser capacity	31
5.3	Operation	31
5.3.1	Switching on the appliance	32
5.3.2	Loading the appliance	33
5.3.3	Moving the appliance	34
5.4	Measures at the End of Operation	34
6	Fault Detection and Troubleshooting	35
6.1	Safety Measures	35
6.2	Notes on Troubleshooting	35
6.3	Fault and Action Table	35
7	Cleaning and Care	37
7.1	Safety Measures	37
7.2	Hygiene Measures	37
7.3	Cleaning and Care	37
7.4	Special Care Instructions	38
8	Spare Parts and Accessories	39
8.1	Introduction	39
8.2	Spare Parts and Accessories List	39
9	Annex	45
9.1	EC Declaration of Conformity	45

1.3 List of Abbreviations

Abbreviation	Definition																																				
BGR	Rule of the Professional Association																																				
BGV	Regulation of the Professional Association																																				
CE	Communauté Européenne European Community																																				
DIN	Deutsches Institut für Normung German Institute for Standardisation, technical regulations and technical specifications																																				
EC	European Community European Union																																				
EN	European Standard Harmonised standard for the EU market																																				
E/V	Spare and wearing part																																				
IP	<p>International Protection. The abbreviation IP and a further two-digit index specify the protection class of a housing.</p> <p>The first digit: Protection against ingress of solid foreign objects The second digit: Protection against ingress of water</p> <table border="1"> <tbody> <tr> <td>0</td> <td>No protection against contact, no protection against ingress of solid foreign objects</td> <td>0</td> <td>No protection against ingress of water</td> </tr> <tr> <td>1</td> <td>Protection against contact with any large surface of the body such as the hand, protection against ingress of foreign objects $\varnothing > 1.97''$ (50 mm)</td> <td>1</td> <td>Protection against vertically falling water drops</td> </tr> <tr> <td>2</td> <td>Protection against contact with the fingers, protection against ingress of foreign objects $\varnothing > 0.5''$ (12 mm)</td> <td>2</td> <td>Protection against dripping water (at any angle up to 15° from the vertical)</td> </tr> <tr> <td>3</td> <td>Protection against contact with tools, thick wires or similar objects of $\varnothing \square > 0.1''$ (2.5 mm) protection against foreign objects $\varnothing \square > 0.1''$ (2.5 mm)</td> <td>3</td> <td>Protection against water drips at any angle up to 60° from the vertical</td> </tr> <tr> <td>4</td> <td>Protection against contact with tools, thick wires or similar objects of $\varnothing \square > 0.04''$ (1 mm) protection against foreign objects $\varnothing \square > 0.04''$ (1 mm)</td> <td>4</td> <td>Protection against water splashing from any direction</td> </tr> <tr> <td>5</td> <td>Protection against contact, protection against dust deposits inside</td> <td>5</td> <td>Protection against water jets (projected by a nozzle) at any angle</td> </tr> <tr> <td>6</td> <td>Complete protection against contact, protection against ingress of dust</td> <td>6</td> <td>Protection against temporary flooding</td> </tr> <tr> <td></td> <td></td> <td>7</td> <td>Protection against ingress of water during temporary immersion</td> </tr> <tr> <td></td> <td></td> <td>8</td> <td>Protection against pressurised water during continuous immersion</td> </tr> </tbody> </table>	0	No protection against contact, no protection against ingress of solid foreign objects	0	No protection against ingress of water	1	Protection against contact with any large surface of the body such as the hand, protection against ingress of foreign objects $\varnothing > 1.97''$ (50 mm)	1	Protection against vertically falling water drops	2	Protection against contact with the fingers, protection against ingress of foreign objects $\varnothing > 0.5''$ (12 mm)	2	Protection against dripping water (at any angle up to 15° from the vertical)	3	Protection against contact with tools, thick wires or similar objects of $\varnothing \square > 0.1''$ (2.5 mm) protection against foreign objects $\varnothing \square > 0.1''$ (2.5 mm)	3	Protection against water drips at any angle up to 60° from the vertical	4	Protection against contact with tools, thick wires or similar objects of $\varnothing \square > 0.04''$ (1 mm) protection against foreign objects $\varnothing \square > 0.04''$ (1 mm)	4	Protection against water splashing from any direction	5	Protection against contact, protection against dust deposits inside	5	Protection against water jets (projected by a nozzle) at any angle	6	Complete protection against contact, protection against ingress of dust	6	Protection against temporary flooding			7	Protection against ingress of water during temporary immersion			8	Protection against pressurised water during continuous immersion
0	No protection against contact, no protection against ingress of solid foreign objects	0	No protection against ingress of water																																		
1	Protection against contact with any large surface of the body such as the hand, protection against ingress of foreign objects $\varnothing > 1.97''$ (50 mm)	1	Protection against vertically falling water drops																																		
2	Protection against contact with the fingers, protection against ingress of foreign objects $\varnothing > 0.5''$ (12 mm)	2	Protection against dripping water (at any angle up to 15° from the vertical)																																		
3	Protection against contact with tools, thick wires or similar objects of $\varnothing \square > 0.1''$ (2.5 mm) protection against foreign objects $\varnothing \square > 0.1''$ (2.5 mm)	3	Protection against water drips at any angle up to 60° from the vertical																																		
4	Protection against contact with tools, thick wires or similar objects of $\varnothing \square > 0.04''$ (1 mm) protection against foreign objects $\varnothing \square > 0.04''$ (1 mm)	4	Protection against water splashing from any direction																																		
5	Protection against contact, protection against dust deposits inside	5	Protection against water jets (projected by a nozzle) at any angle																																		
6	Complete protection against contact, protection against ingress of dust	6	Protection against temporary flooding																																		
		7	Protection against ingress of water during temporary immersion																																		
		8	Protection against pressurised water during continuous immersion																																		
LED	Light Emitting Diode Light diode																																				

1.4 Definitions of Terms

Term	Definition
Authorised specialist	An authorised specialist is a specialist that has been trained by the manufacturer, an authorised service dealer or a company assigned by the manufacturer.
Cover	A bell-shaped cover for keeping food warm on plates and dishes.
Cook&Chill Kitchens	"Cook and Chill": Kitchens where warm food after being cooked is chilled as quickly as possible.
Cook&Serve Kitchens	"Cook and Serve": Kitchens where warm food is served immediately after being cooked or kept warm until it is consumed.
Element formation	Also: contact corrosion. Occurs when different noble metals are in close contact with each other. This happens when a corrosive medium is between both metals, as for example water or even air humidity.
Specialist	A specialist is a person who can evaluate work assigned and can individually recognise any possible dangers due to professional training, specialist knowledge and experience as well as knowledge of the respective guidelines.
Lift	A movement, for example a vertical movement of the guide basket from bottom to top.
Control	Compare with certain conditions and/or characteristics such as damage, leaks, filling levels, heat.
Convection	Physical properties or mass transfer (e.g. heat or cold) through currents in gases and liquids.
Corrosion	The chemical reaction of a metallic material with its surroundings, e.g. rust.
Machine safety	The term of machine safety means all the measures used to avert injury to persons. The basis for this are national as well as EC-wide valid directives and laws for protecting users of technical devices and systems.
Passive layer	A non-metallic protective layer on a metallic material that prevents or slows down material corrosion.
Check	Compare with certain values such as weight, torque, content, temperature.
Qualified person, qualified staff	Qualified personnel are persons who due to their professional training, experience and instruction as well as their knowledge of the respective standards, guidelines, accident prevention regulations and operating conditions have been authorised by a person responsible for system safety to carry out required activities and can recognise and prevent any possible danger (definition of specialists according to IEC 364).
Schuko®	The abbreviation of the German term "Protective contact" that indicates a system of domestic plugs and sockets equipped with protective earthed contacts used in most of Europe.
Instructed persons	An instructed person is a person who has been instructed on the possible risks resulting from improper behaviour when carrying out the assigned task as well as on the necessary protective equipment and protective measures and trained for this task if necessary.

1.5 Orientation Guide

The front

"The front" means the side of the plate dispenser where the push bars are arranged. The operating staff stays at this side to move the appliance.

The side of the built-in appliances named as "the front" means the side, at which the staff operates the plate dispenser.

The rear

The side named "the rear" means the opposite side of the front side (the front).

The right

The side named "the right" means the side at the right hand side of the front side (the front).

The left



The side named "the left" means the side at the left hand side of the front side (the front).

1.6 Notes on Use of Manual

1.6.1 Notes on the Manual Structure

This manual is structured in functional and task orientated chapters.

1.6.2 Notes and their Illustrations used in the Chapters

DANGER	Brief description of danger
	<p>There is an imminent danger to life and limb of the user and / or third parties when the instructions are not followed precisely or the circumstances described are not taken into account.</p> <p>The type of danger is indicated by a symbol and explained in the accompanying text in more detail. In this example the general sign of danger is used.</p>
WARNING	Brief description of danger
	<p>There is an indirect danger to life and limb of the user and / or third parties when the instructions are not followed precisely or the circumstances described are not taken into account.</p> <p>The type of danger is indicated by a symbol and explained in the accompanying text in more detail. In this example the general sign of danger is used.</p>
ATTENTION	Brief description of danger
	<p>There is a potential risk of injury or damage to property when the instructions are not followed precisely or the circumstances described are not taken into account.</p> <p>The type of danger is indicated by a general sign and explained in the accompanying text in more detail. In this example the general sign of danger is used.</p>
NOTE	Brief description of additional information
	Attention is pointed to special conditions or additional important information on the respective subject.
INFO	Short title
	Contains additional information on work assisting features or recommendations on the respective subject.

2 Safety Instructions







2.1 Introduction

The chapter on safety instructions describes the risks associated with the appliance in terms of product liability (according to the EU Directive).

2.2 Warning Symbols Used

Symbols are used in these operating instructions to point out the dangers that can occur while operating or cleaning the appliance. In both cases, the symbol provides information on the type and circumstances of danger.

The following symbols can be used:

	General hazardous area
	Hazardous electrical voltage
	Risk of hand injuries
	Risk of crushing
	Risk of hot surfaces
	Wear hand protection

2.3 Safety Instructions for Appliance Safety

Safe operation of the appliance depends on appropriate and thorough use. Negligent handling of the appliance can lead to danger to life and limb of the user and / or third parties as well as hazards to the appliance itself and the other operator's property.

2.3.1 Safety instructions for all appliances

The following points are to be observed to ensure the appliance safety:

- The appliance may only be operated when it is in perfect condition with regards to technical standards.
- All the operating and actuating elements must be in a perfect and functionally reliable condition with regards to technical standards.
- Modifications or retrofits of the equipment are only permitted in consultation with the manufacturer and on receipt of his written agreement.
- In no case may people sit or stand on the appliance. Transport of persons is not permitted.
- Before loading, the crockery dispensing height must be adjusted to the kind of crockery used.
- The crockery guides must be adjusted to the kind of crockery used before loading.
- To avoid injuries to the hands, care should always be taken to ensure that the crockery dispensing height does not fall below the upper rim of the housing.
- Never push the guide basket down manually into the dispensing tube (e.g. for cleaning). There is a risk of injury, if the guide basket is released.

- The appliance is provided exclusively for manual transport. Transport using any kind of devices is not permitted. Risk of injury and damage.
- If a stack of plates with the covers is too high, do not push it down forcibly. There is a risk of injury, if the locking is released. Furthermore, the locking function of the covers can be damaged.
- Release both brakes before commencing transporting. Moving the appliance with the applied locking brakes can damage the chassis!
- Transport should only be undertaken over level floors. Moving the appliance over very uneven floors can damage the chassis.
- Transport over inclined planes or steps is not permitted.
- When approaching walls and moving round obstacles always pay attention to persons in the way. Risk of injury.
- When transporting the appliance, always hold both handles with your hands. Never let go of the appliance while moving it.
- When transporting the appliance, do not move it faster than a walking pace. Heavily laden plate dispensers are difficult to brake and steer. If necessary, ask for assistance when transporting the appliance.
- If the plate dispenser tips over due to outside influences or inattention, never catch it manually. Risk of injury.
- Do not stop the appliance on sloping floors.
- After stopping, the appliance should be secured against rolling away by means of both brakes being applied.
- In the case of off-site transport in a vehicle such as a lorry, the appliances should be secured properly. The brakes are not sufficient as a transport securing method.

2.3.2 Additional safety instructions for heated appliances

- The heated appliances can only be operated by instructed specialists and kitchen staff and under continuous supervision.
- Heated plate dispensers are intended for dispensing heated crockery. Their use for cooking food and keeping it warm or for room heating is not permitted.
- The crockery temperatures can exceed the permitted maximum temperatures of 149°F (65°C) for touchable appliance surfaces. Always wear protective gloves when dispensing hot crockery. Risk of burning.
- During operation of the appliance, never reach into it and touch the heating element with the fingers. Risk of burning.
- Plastic crockery, top and bottom parts of plastic insulated sets and plastic-coated items for keeping food warm should not be stored or warmed up in heated plate dispensers. Owing to the high temperatures of the heating elements, the plastics can melt and catch fire.
- The base plate and used air from the base outlets can become very hot. The appliance should not be operated on fibre-based floor coverings (e.g. carpets, mats).
- Before transporting, switch off the appliance, pull out the mains plug and insert it into the holder provided.
- Forceful straining of the lead can lead to damage to the internal line. Risk of fire.
- Never pull the mains plug out of the socket by the lead. The standard models of HUPFER® appliances are equipped with a Schuko® angle plug. In contrast to a straight Schuko® plug this plug only sticks insignificantly out of the socket and so cannot be damaged by being hit at the side. If the appliance is moved without pulling out the mains plug beforehand, the socket can be severely damaged or even pulled out from the wall as a result of leverage arising from overstretching of the lead.
- Never move the appliance by pulling by the lead.
- If the mains plug has come into contact with water it must be dried before inserting it into the socket. Danger to life.
- Damaged mains plugs or leads are to be replaced by authorised personnel before the appliance is reused.

- Do not use any extension leads in wet and damp areas.
- Only insert mains plugs into suitable sockets. If the mains plug does not fit, the lead of the appliance is to be retrofitted by authorised specialist staff.
- The use of socket adapters is not permitted. Risk of fire.
- Do not clean the appliance with steam-jet or high-pressure washers. The appliance must be taken out of operation and switched off at the mains beforehand in any area where steam-jet or high-pressure washers are to be used.

2.4 Safety Instructions for Cleaning and Care

The following points must be observed when carrying out any cleaning and maintenance operations:

- For reasons of hygiene the cleaning instructions must be strictly observed.
- Take the appliance out of operation before starting the cleaning process. Pull out the mains plug and insert it into the holder located on the appliance.
- For cleaning, the appliance must be out of operation and cooled down sufficiently.
- Do not clean the appliance with steam-jet or high-pressure washers. The appliance must be taken out of operation and switched off at the mains beforehand in any area where steam-jet or high-pressure washers are to be used.
- Even appliances without an electrical connection should not be cleaned with running water or pressurised water.

2.5 Safety Instructions for Troubleshooting

The following points shall be observed when carrying out any maintenance and troubleshooting operations:

- All troubleshooting work should only be carried out by authorised specialists.
- When carrying out troubleshooting work, it must be ensured that the appliance is switched off. When working on the electrical installation, the appliance must be switched off at the mains and secured against reactivation.
- The local applicable Accident Prevention Regulations must be observed.
- Defective components should only be replaced with original parts.

2.6 Notes on Specific Hazards

Electrical energy

- All work on the electrical installations should only be carried out by a certified electrician or by authorised specialists under supervision and monitoring of a certified electrician according to the applicable electro-technical regulations.
- The appliances on which inspection, maintenance and troubleshooting work is performed must be disconnected from the power supply and secured against reactivation when the voltage is not required for this kind of work. This must only be carried out by a certified electrician.

3 Description and Technical Data

3.1 Performance Description

Plate dispensers are intended for storage of clean crockery items ready for use in the food service industry and large-scale catering establishments. They are used mainly for storage of warmed crockery ready for use on food distribution belts and storage of plates at normal temperature or chilled on self-service counters in bistros or cafeterias.

There are various models available for selection. Depending upon the size and number of crockery items, the plate dispensers are available in two sizes, 19-26 (for plates with a diameter of 7.48" to 10.24") and 27-33 (for plates with a diameter of 10.63" to 13").

The unheated models with the enclosed side and front walls of the housing store crockery items ready for use for serving portions of cold dishes.

The unheated models with cooling slots store crockery ready for serving portions of cold side dishes, e.g. salads and desserts.

The models heated by air circulation are intended for storage of crockery ready for serving portions of warm components. The crockery can be heated up to 212°F (100°C).

Besides the mobile plate dispensers, there are plate dispensers intended for installation in worktops.

3.2 Intended Use

Plate dispensers are intended exclusively for storage of clean plates with diameter of 7.48" to 10.24" or 10.63" to 13" ready for use. Depending on the model, the loaded plates can be cooled down or heated up.

The appliances are intended for transporting round china items or transport made of toughened glass. Transport of other loads is not permitted.

The intended use means the predetermined procedures, compliance with the indicated specifications and use of the delivered or additionally available original accessories.

Any other use of the appliance is considered as unintended use.

3.3 Improper Use

It is not permitted to load the plate dispenser with other loads as given.

In no case may people sit or stand on the appliance or be transported on it.

Moreover, it is not permitted to use the heated plate dispensers for cooking food or keeping it warm and for room heating.

No flammable or outgassing objects, objects with plastic items or foodstuff should be stored under the plate dispenser.

No liability is assumed and no warranty claims can be submitted for damages caused by improper use.

3.4 Appliance Description

3.4.1 View of the appliance - Plate dispenser

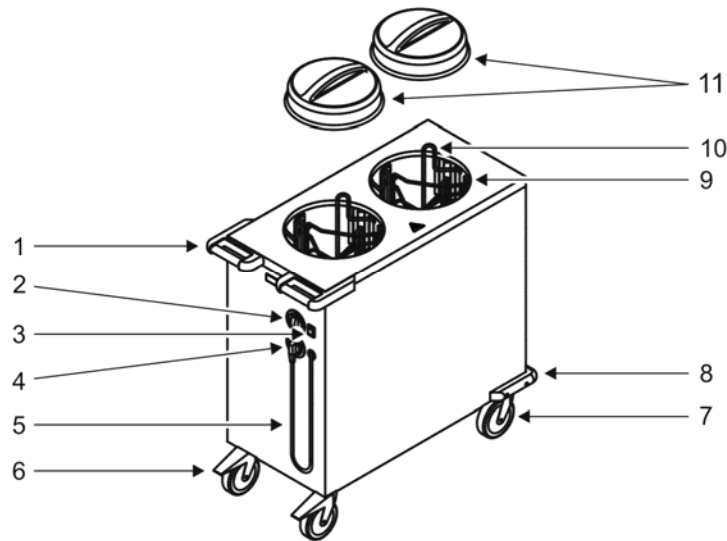

Figure 1 View of the appliance

- | | |
|---|---------------------------------|
| 1 Push bar | 7 Swivel casters without brakes |
| 2 Thermostat for setting the temperature* | 8 Corner bumpers |
| 3 On / Off switch* | 9 Guide basket |
| 4 Plug park (dummy socket)* | 10 Crockery guide |
| 5 Lead with mains plug* | 11 Cover* |
| 6 Swivel casters with brakes | |
- * heated appliances only

3.4.2 View of the appliance - Built-in plate dispenser

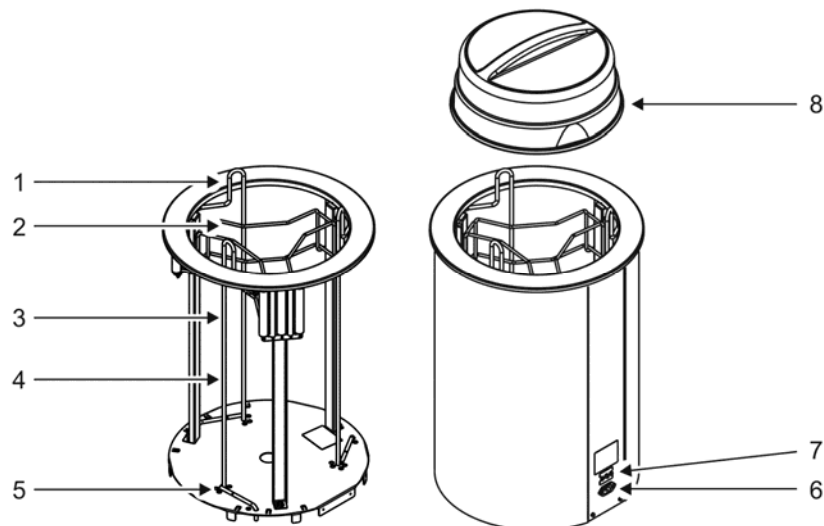

Figure 2 View of the appliance

- | | |
|--|--|
| 1 Crockery guide | 5 Locking positions for the crockery guide |
| 2 Guide basket | 6 Connecting socket for appliance plug* |
| 3 Attachment bar with adjustable springs | 7 Thermostat* |
| 4 Guide rail | 8 Cover* |
- * heated appliances only

3.4.3 Appliance description

The plate dispensers accommodate clean chinaware and plates made of toughened glass in a adjustable, spring-loaded guide basket. Owing to the use of special springs, crockery items are moved automatically and constantly over the entire lift upwards to a uniform dispensing height.

If necessary, there are various models available. A plate dispenser model 19-26 is particularly suitable for plates with diameter of 7.48" to 10.24". A plate dispenser model 27-33 is particularly suitable for plates with diameter of 10.63" to 13".

All the plate dispensers are universally adjustable appliances suitable for the plate diameters, stack heights and weights given above. The ergonomically favourable dispensing height can be adjusted within a limit to persons of different height. Plate dispensers are available as one-tube and two-tube models.

Unheated appliances with enclosed side and front walls store crockery at normal temperature ready for use. Unheated appliances with cooling slots are particularly suitable to be used in cold stores. When used in the cold store, the cooling slots arranged on the side and front walls of the appliance housing ensure a rapid exchange of air and cause the cold air to be distributed uniformly inside.

The appliances with electric heating (static or circulating air) pre-warm the plates or heat them up to a pre-set temperature.

Besides the mobile plate dispensers, there are built-in plate dispensers intended for installation in worktops. Depending on the purpose, the built-in appliances are available in different sizes, as one and two-tube models and heated or unheated.

The operating temperature can be continuously set on the heated plate dispensers. The controller is arranged on the front of the housing and can be adjusted as required when using built-in appliances.

The covers made of plastic protect the crockery against dust and condensed water even during relatively long periods of temporary storage. Using a cover in the heated appliances lowers the heat loss upwards and reduces the heating time of the inserted crockery or delays the cooling of pre-warmed crockery. The cover is included in the scope of delivery of the heated models.



3.4.4 Optional accessories



The following parts can be applied as optional accessories for the plate dispenser:

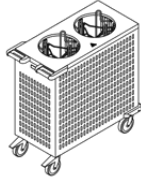

- Cover Ø 7.48"-10.24" high for plate dispenser model 19-26
- Cover Ø 7.48"-10.24" flat for TEUH-2/VC 19-26 (not suitable for other models)
- Cover Ø 10.63"-13" for plate dispenser model 27-33
- Swivel casters made of stainless steel, Ø 4.92" with and without brakes, plate attachment

The part numbers of the special accessories can be found in the spare parts catalogue and order lists available online.

3.5 Technical Data

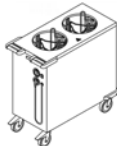
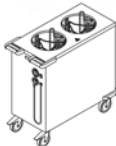
	Dim.	TE-2/V19-26	TE-2/V27-33	TE-2/VK19-26
View of the appliance				
		Plate dispenser, unheated and without cooling device	Plate dispenser, unheated and without cooling device	Plate dispenser, unheated with cooling device
Own weight	lbs (kg)	68.3 (31)	70.5 (32)	63.9(29)
Payload	lbs (kg)	308 (140)	308 (140)	308 (140)
Permitted total weight	lbs (kg)	376.9 (171)	379.1 (172)	372.5 (169)
Overall dimensions w x d x h	in (mm)	18.1 x 36.8 x 35.4 (460 x 935 x 900)	20.8 x 41.5 x 35.4 (530 x 1055 x 900)	18.1 x 36.8 x 35.4 (460 x 935 x 900)
Operating and ambient conditions	°C (°F)	-20 to 50 (68 to 122)	-20 to 50 (68 to 122)	-20 to 50 (68 to 122)
Chassis	in (mm)	4 swivel casters, 2 of them with brakes, Ø 5" (125 mm)	4 swivel casters, 2 of them with brakes, Ø 5" (125 mm)	4 swivel casters, 2 of them with brakes, Ø 5" (125 mm)
Crockery guide		3 adjustable guides per tube, plastic-coated	3 adjustable guides per tube, plastic-coated	3 adjustable guides per tube, plastic-coated
Guide basket	in (mm)	Rod construction, plastic-coated	Rod construction, plastic-coated	Rod construction, plastic-coated
Stack height without cover	in (mm)	26.3 (670)	26.3 (670)	26.3 (670)
Stack height with cover	in (mm)	29.1 (740)	29.1 (740)	29.1 (740)
Crockery size	in (mm)	Ø 7.48-10.24 (190-260)	Ø 10.63-13 (270-330)	Ø 7.48-10.24 (190-260)
Capacity given in items (depending on the stack height)		up to 144 (without cover) and 166 (with cover)	up to 106 (without cover) and 122 (with cover)	up to 144 (without cover) and 166 (with cover)
Number of crockery stacks		2	2	2

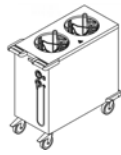
	Dim.	TEH-1/V19-26	TEH-1/V27-33	TEH-2/V19-26	TEH-2/V27-33
View of the appliance					
		Plate dispenser, heated	Plate dispenser, heated	Plate dispenser, heated	Plate dispenser, heated
Own weight	lbs (kg)	66.1 (30)	77.1 (35)	90.3 (41)	112.4 (51)
Payload	lbs (kg)	154.3 (70)	176.3 (80)	308.6 (140)	308.6 (140)
Permitted total weight	lbs (kg)	220.4 (100)	253.5 (115)	399 (181)	421 (191)
Overall dimensions w x d x h	in (mm)	18.1 x 24 x 35.4 (460 x 610 x 900)	20.8 x 27.9 x 35.4 (530 x 710 x 900)	18.1 x 36.8 x 35.4 (460 x 935 x 900)	20.8 x 41.5 x 35.4 (530 x 1055 x 900)
Operating and ambient conditions	°C (°F)	-20 to 50	-20 to 50	-20 to 50	-20 to 50
Chassis	in (mm)	4 swivel casters, 2 of them with brakes, Ø 5" (125 mm)	4 swivel casters, 2 of them with brakes, Ø 5" (125 mm)	4 swivel casters, 2 of them with brakes, Ø 5" (125 mm)	4 swivel casters, 2 of them with brakes, Ø 5" (125 mm)
Crockery guide		3 adjustable guides per tube, plastic-coated	3 adjustable guides per tube, plastic-coated	3 adjustable guides per tube, plastic-coated	3 adjustable guides per tube, plastic-coated
Guide basket	in (mm)	Rod construction, plastic-coated	Rod construction, plastic-coated	Rod construction, plastic-coated	Rod construction, plastic-coated
Stack height without cover	in (mm)	26.3 (670)	26.3 (670)	26.3 (670)	26.3 (670)
Stack height with cover	in (mm)	29.1 (740)	29.1 (740)	29.1 (740)	29.1 (740)
Crockery size	in (mm)	Ø 7.48-10.24 (190-260)	Ø 10.63-13 (270-330)	Ø 7.48-10.24 (190-260)	Ø 10.63-13 (270-330)
Capacity given in items (depending on the stack height)		up to 72 (without cover) and 83 (with cover)	up to 53 (without cover) and 61 (with cover)	up to 144 (without cover) and 166 (with cover)	up to 106 (without cover) and 122 (with cover)
Number of crockery stacks		1	1	2	2
Heating		Stainless steel tubular heating element	Stainless steel tubular heating element	Stainless steel tubular heating element	Stainless steel tubular heating element
Thermostat setting	°F (°C)	86-239 (30-115)	86-239 (30-115)	86-239 (30-115)	86-239 (30-115)
Maximum crockery temperature	°F (°C)	158 (70)	158 (70)	176 (80)	176 (80)
Temperature regulation		continuous	continuous	continuous	continuous
Heat insulation		ceramic mat	ceramic mat	ceramic mat	ceramic mat
Electrical connection		230 V 1N AC 50 Hz	230 V 1N AC 50 Hz	230 V 1N AC 50 Hz	230 V 1N AC 50 Hz
Power requirement	kW	0.9	0.9	0.9	1.5
Protection class		IPX5	IPX5	IPX5	IPX5

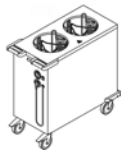
	Dim.	TEUH-1/VS19-26	TEUH-2/VS19-26	TEUH-2/VS27-33	TEUH-2/VC19-26
View of the appliance					
		Plate dispenser, heated	Plate dispenser, heated	Plate dispenser, heated	Plate dispenser, heated
Own weight	lbs (kg)	68.3 (31)	90.3 (41)	112.4 (51)	121.2 (55)
Payload	lbs (kg)	154.3 (70)	308.6 (140)	308.6 (140)	308.6 (140)
Permitted total weight	lbs (kg)	222.6 (101)	399 (181)	421 (191)	429.8 (195)
Overall dimensions w x d x h	in (mm)	18.1 x 24 x 35.4 (460 x 610 x 900)	18.1 x 36.8 x 35.4 (460 x 935 x 900)	20.8 x 41.5 x 35.4 (530 x 1055 x 900)	20 x 37.7 x 35.4 (510 x 960 x 900)
Operating and ambient conditions	°F (°C)	68 to 122 (20 to 50)	68 to 122 (20 to 50)	68 to 122 (20 to 50)	68 to 122 (20 to 50)
Chassis	in (mm)	4 swivel casters, 2 of them with brakes, Ø 5" (125 mm)	4 swivel casters, 2 of them with brakes, Ø 5" (125 mm)	4 swivel casters, 2 of them with brakes, Ø 5" (125 mm)	4 swivel casters, 2 of them with brakes, Ø 5" (125 mm)
Crockery guide		3 adjustable guides per tube, plastic-coated	3 adjustable guides per tube, plastic-coated	3 adjustable guides per tube, plastic-coated	3 adjustable guides per tube, electropolished
Guide basket	in (mm)	Rod construction, plastic-coated	Rod construction, plastic-coated	Rod construction, plastic-coated	Rod construction, electropolished
Stack height without cover	in (mm)	26.3 (670)	26.3 (670)	26.3 (670)	23 (585)
Stack height with cover	in (mm)	29.1 (740)	29.1 (740)	29.1 (740)	24.2 (615)
Crockery size	in (mm)	Ø 7.48 -10.24 (190-260)	Ø 7.48 -10.24 (190-260)	Ø 10.63-13 (270-330)	Ø 7.48 -10.24 (190-260)
Capacity given in items (depending on the stack height)		up to 72 (without cover) and 83 (with cover)	up to 144 (without cover) and 166 (with cover)	up to 106 (without cover) and 122 (with cover)	up to 130 (without cover) and 138 (with cover)
Number of crockery stacks		1	2	2	2
Heating		Power module	Power module	Power module	Power module
Thermostat setting	°F (°C)	86-239 (30-115)	86-239 (30-115)	86-239 (30-115)	86-239 (30-115)
Maximum crockery temperature	°F (°C)	176 (80)	176 (80)	176 (80)	212 (100)
Temperature regulation		continuous	continuous	continuous	continuous
Heat insulation		special insulation	special insulation	special insulation	special insulation
Electrical connection		230 V 1N AC 50 Hz	230 V 1N AC 50 Hz	230 V 1N AC 50 Hz	230 V 1N AC 50 Hz
Power requirement	kW	0.9	1.5	1.5	2.0
Protection class		IPX5	IPX5	IPX5	IPX5

Built-in plate dispenser

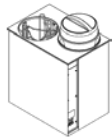
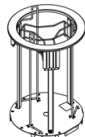
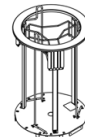
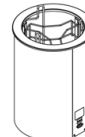
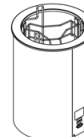
	Dim.	EBRH-2/V19-26	EBR/V19-26	EBR/V27-33	EBRH/V19-26	EBRH/V27-33
View of the appliance						
Own weight	lbs (kg)	59.5 (27)	13.2 (6)	15.4 (7)	30.8 (14)	37.4 (17)
Payload	lbs (kg)	308.4 (140)	121.2 (55)	132.2 (60)	121.2 (55)	132.2 (60)
Permitted total weight	lbs (kg)	368.1 (167)	134.4 (61)	147.7 (67)	152.1 (69)	169.7 (77)
Overall dimensions w x d x h Ø x h	in (mm)	24.6 x 17.1 x 25.5 (626 x 435 x 650)	15.7 x 25.5 (400 x 650)	18.5 x 25.5 (470 x 650)	15.7 x 25.5 (400 x 650)	18.5 x 25.5 (470 x 650)
Operating and ambient conditions	°F (°C)	68 to 122 (20 to 50)	68 to 122 (20 to 50)	68 to 122 (20 to 50)	68 to 122 (20 to 50)	68 to 122 (20 to 50)
Crockery guide		3 adjustable guides per tube, plastic-coated	3 adjustable guides per tube, plastic-coated	3 adjustable guides per tube, plastic-coated	3 adjustable guides per tube, plastic-coated	3 adjustable guides per tube, plastic-coated
Guide basket	in (mm)	Rod construction, plastic-coated	Rod construction, plastic-coated	Rod construction, plastic-coated	Rod construction, plastic-coated	Rod construction, plastic-coated
Stack height without cover	in (mm)	17.9 (455)	19.4 (495)	19.4 (495)	19.4 (495)	19.4 (495)
Stack height with cover	in (mm)	21.8 (555)	24.8 (630)	24.8 (630)	24.8 (630)	24.8 (630)
Crockery size	in (mm)	Ø 7.48-10.24 (190-260)	Ø 7.48-10.24 (190-260)	Ø 10.24-13 (270-330)	Ø 7.48-10.24 (190-260)	Ø 10.24-13 (270-330)
Capacity given in items (depending on the stack height)		up to 120 (without cover) and 140 (with cover)	up to 72 (without cover) and 83 (with cover)	up to 44 (without cover) and 52 (with cover)	up to 144 (without cover) and 166 (with cover)	up to 106 (without cover) and 122 (with cover)
Number of crockery stacks		2	1	1	1	1
Heating		Stainless steel tubular heating element	-	-	Stainless steel tubular heating element	Stainless steel tubular heating element
Thermostat setting	°F (°C)	86-239 (30-115)	-	-	68-185 (20-85)	68-185 (20-85)
Maximum crockery temperature	°F (°C)	158 (70)	-	-	176 (80)	176 (80)
Temperature setting		continuous	-	-	continuous	continuous
Heat insulation		ceramic mat	-	-	ceramic mat	ceramic mat
Electrical connection		230 V 1NAC 50 Hz	-	-	230 V 1NAC 50 Hz	230 V 1NAC 50 Hz

	Dim.	EBRH-2/V19-26	EBR/V19-26	EBR/V27-33	EBRH/V19-26	EBRH/V27-33
Power requirement	kW	1.0	-	-	0.6	0.6
Protection class		IPX4	-	-	IPX4	IPX4

The corresponding test marks can be found on our homepage at www.hupfer.de.

3.6 Rating Plate

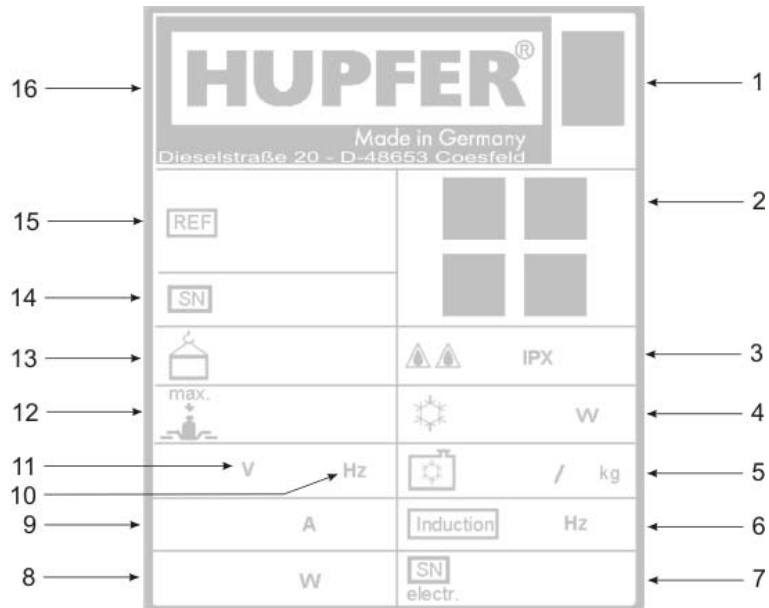

Figure 3 Rating plate

- | | | | |
|---|----------------------------|----|----------------------------|
| 1 | Disposal of old appliances | 9 | Nominal current |
| 2 | Certificates/label | 10 | Frequency |
| 3 | Protection class | 11 | Nominal voltage |
| 4 | Chilling capacity | 12 | Payload |
| 5 | Coolant | 13 | Own weight |
| 6 | Induction frequency | 14 | Serial number/Order number |
| 7 | Current serial number | 15 | Item and brief description |
| 8 | Electric power | 16 | Manufacturer |

4 Transport, Assembly, Putting into Operation and Decommissioning

4.1 Transport

ATTENTION

Appliance damages caused by improper transport



In the case of off-site transport in a vehicle such as a lorry, the appliances should be secured properly. The brakes are not sufficient as a transport securing method.

If the appliances are not secured properly, there is a risk of damage to property and persons caused by squashing.

During transport, secure all the individually standing appliances using corresponding transport securing devices.

4.2 Assembly (Built-in appliances only)

ATTENTION

Exposed springs



When pressing down the stacking platform manually, the springs are exposed. Reaching into the gaps of the exposed springs may cause hand injuries.

Never press the stacking platform down manually.

Be careful when hooking and unhooking the springs. When adjusting springs on sharp edges, pay particular attention to the ends of the tension springs.

The following section describes the assembly of the built-in plate dispenser.

Primarily, the unheated appliances EBR/V19-26 and EBR/V27-33 are described that do not require any electrical installations after the assembly.

Subsequently, there follows the assembly description of the heated appliances EBRH/V19-26, EBRH/V27-33 and EBRH-2/19-26 that must be connected to the power supply after the assembly.

4.2.1 Unheated appliances (EBR/V19-26 | EBR/V27-33)

NOTE

Appliance location

Built-in appliances may only be used after being retrofitted or built-in (e.g. in a cabinet).

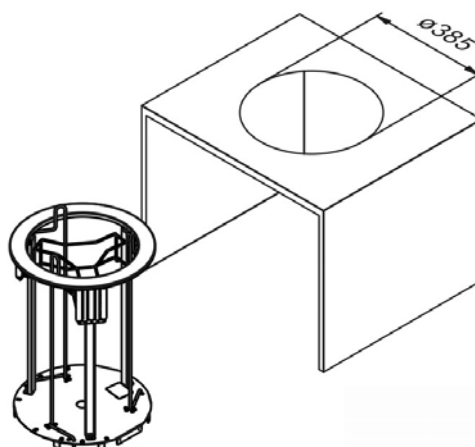

Figure 4

Worktop cut-out EBR/V19-26

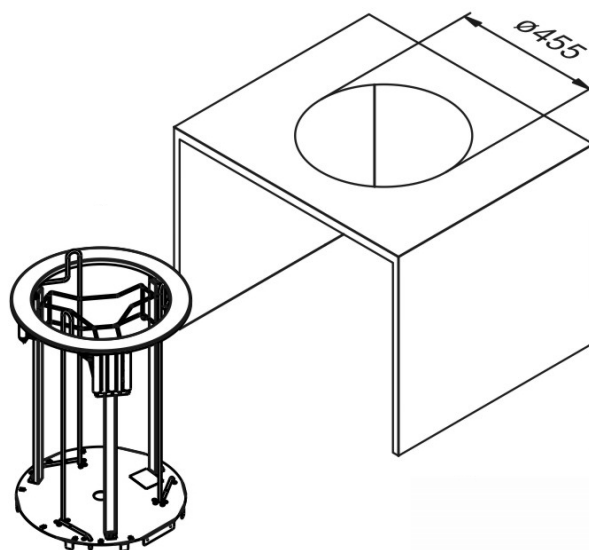

Figure 5 Worktop cut-out EBR/V27-33

Step 1: Preparation

- Prepare cut-outs in the worktop corresponding to the indicated dimensions. The worktop cut-out dimensions are given in mm as shown in the drawing.
- Remove the protective plastic film from the metal plates.

Step 2: Installation

EBR/V19-26

- Insert the appliance into the worktop cut-out from above and fasten it.

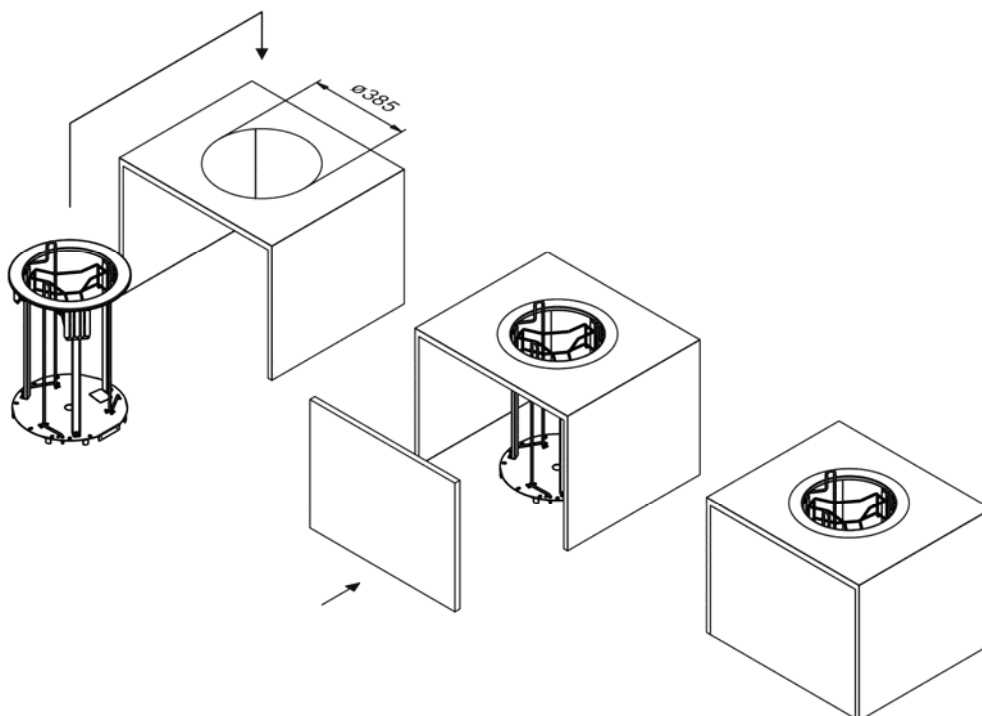

Figure 6 Assembly instructions EBR/V19-26

EBR/V27-33

- Insert the appliance EBR/V27-33 into the worktop cut-out from above and fasten it.

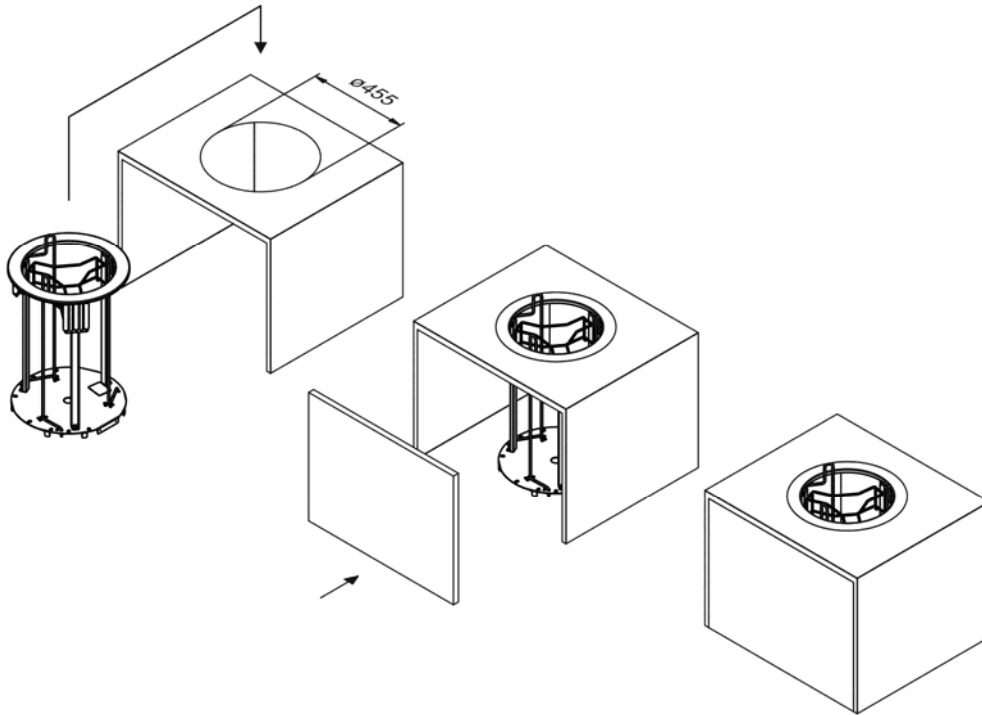



Figure 7 Assembly instructions EBR/V27-33

4.2.2 Heated appliances (EBRH/V19-26 | EBRH/V27-33 | EBRH-2/19-26)

DANGER	Hazardous electrical voltage
	<p>The electrical voltage may be considerably dangerous to limb and life of persons and lead to injuries.</p> <p>All work on the electrical installations should only be carried out by a certified electrician or by authorised specialists under supervision and monitoring of a certified electrician according to the applicable electro-technical regulations.</p>
ATTENTION	Risk of hot surfaces
	<p>The internal surfaces and base plates of the heated appliances can become hot during and/or after the operation. The heated appliances should not come into contact with light inflammable materials.</p> <p>Ensure that there is enough space between the housing and cladding required for air circulation.</p>
NOTE	Appliance location
	<p>The built-in appliances may only be put into operation after being retrofitted or built-in (e.g. in a cabinet).</p>

There is a lead set with a wiring diagram attached to the built-in heated appliances. The set consists of a lead with a Schuko® plug and a lead with a mains plug fitted on the appliance. The leads are wired up with the on/off switch with an integrated indicator light.

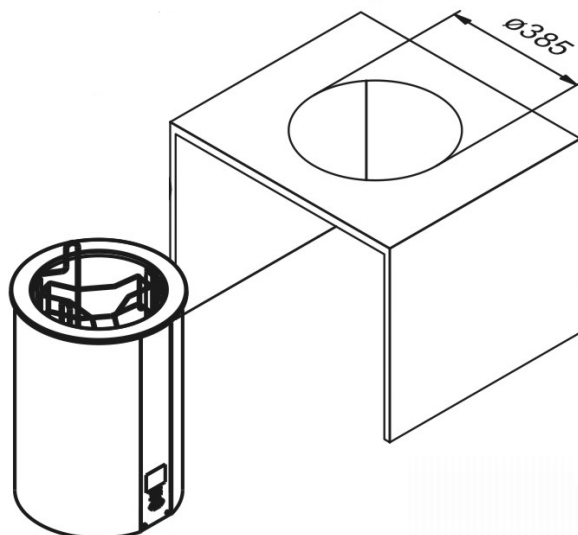

Figure 8 Worktop cut-out EBRH/V19-26

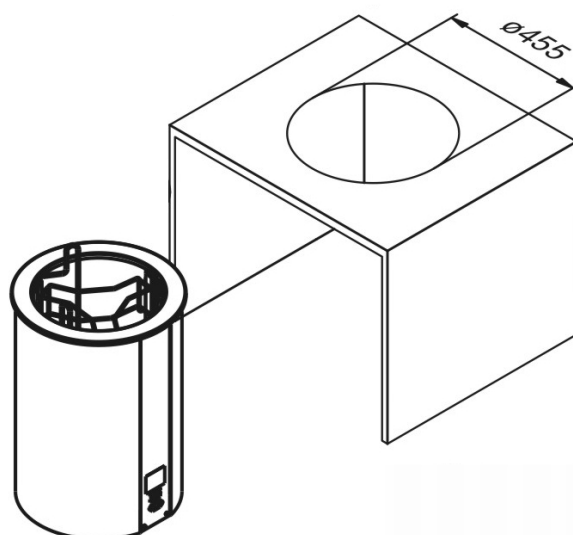

Figure 9 Worktop cut-out EBRH/V27-33

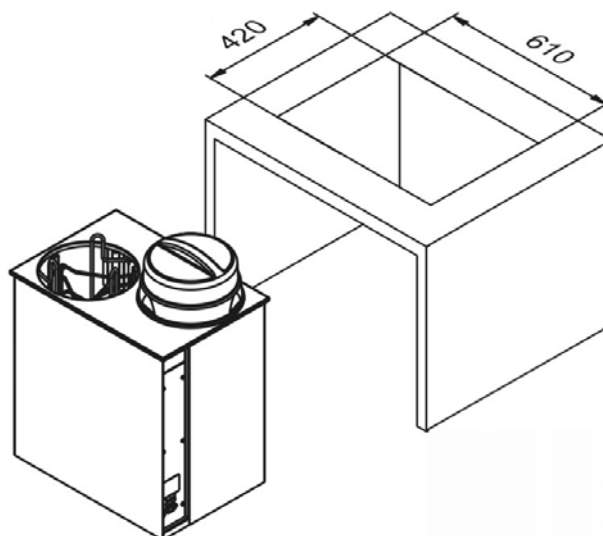

Figure 10 Worktop cut-out EBRH-2/V19-26

Step 1: Preparation

- Prepare cut-outs in the worktop and the front cladding corresponding to the indicated dimensions. The worktop cut-out dimensions are given in inch (mm) as shown in the corresponding drawing of the built-in appliance. The cut-out dimension for the switch is 1.2" x 0.9" (30x22 mm).
- Remove the protective plastic film from the metal plates.

Step 2: Installation

NOTE

Presetting the operating temperature

In contrast to the mobile appliances with the switch and controller arranged next to each other, the switch of the built-in appliance can be placed anywhere on the front side.

Under these circumstances, the controller is no longer accessible for operating after the installation. Ensure that the desired temperature is set on the thermostat before the installation.

- Insert the appliance into the worktop cut-out and fasten it.

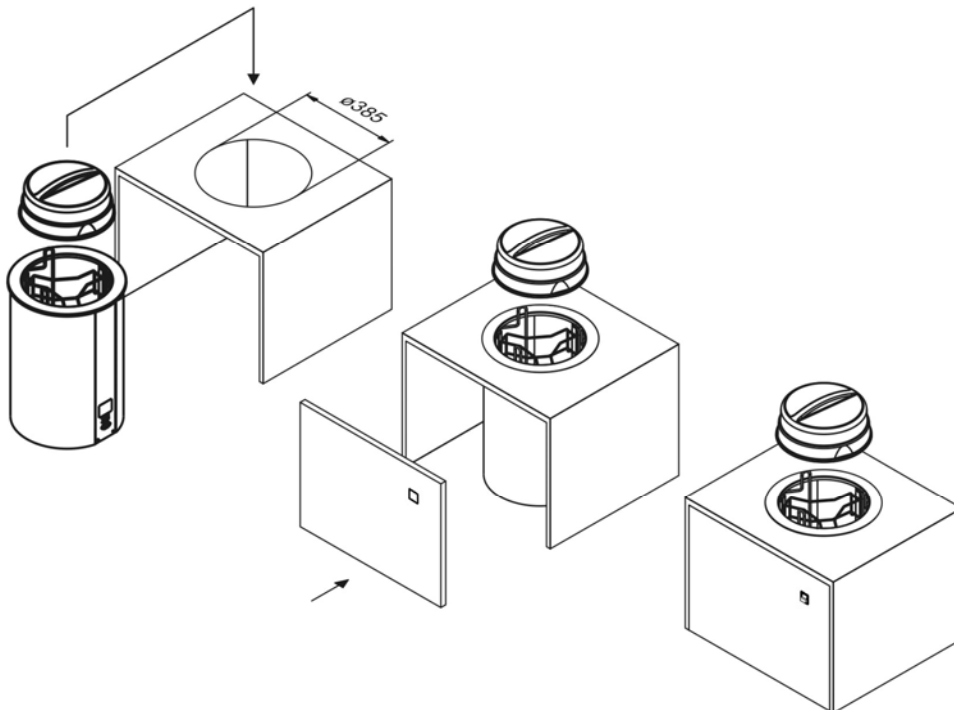

Figure 11

Worktop cut-out EBRH/V19-26

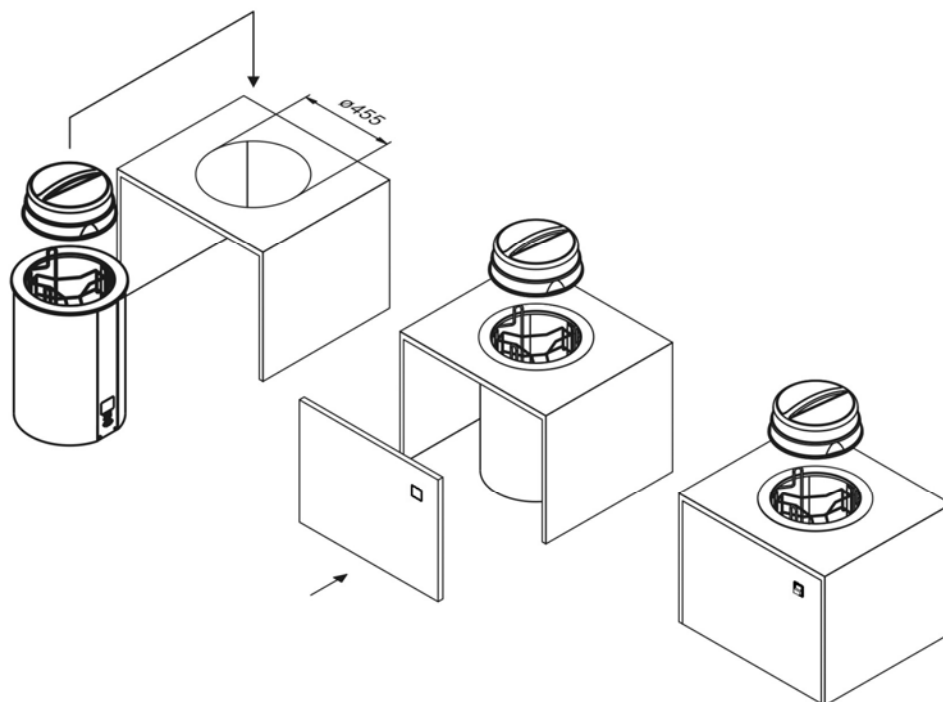

Figure 12 Worktop cut-out EBRH/V27-33

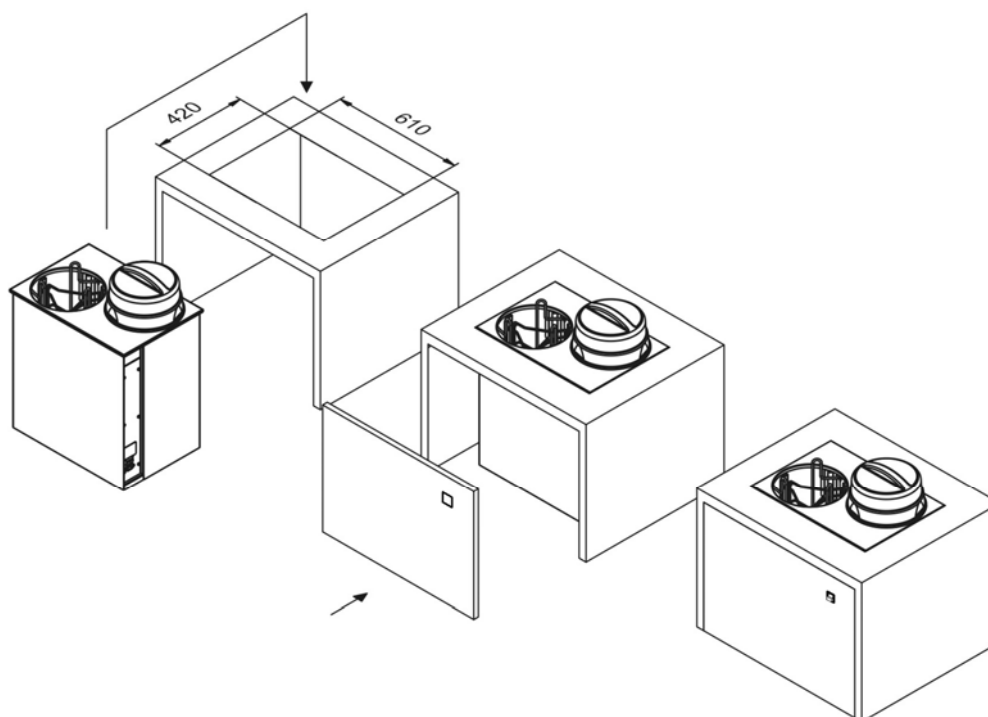

Figure 13 Worktop cut-out EBRH-2/V19-26

Step 3: Connect

- Connect the appliance according to the wiring diagram: Insert the appliance plug of the lead set into the socket of the plate dispenser and the mains plug of the lead set into the on-site power supply socket.
- Put thermally insulating plates around the appliance.

The appliance is ready to be put into operation.

4.3 Putting into Operation

Before the appliance is put into operation it must be clean and dry. Before the first use of the appliance, remove the protective plastic film from the metal plates.

The following appliance functions must be checked before putting it into operation:

- In the mobile appliances: the functioning of the brake.
- In the heated appliances: the functioning of the operating elements and heating.

INFO	Disposal of packing material
The packing consists of recyclable materials and can be disposed of appropriately. Thereby, the different materials are to be separated and disposed in an environmentally compatible manner. In any case, the local bodies responsible for disposal are to be involved for this purpose	

4.4 Storage and Recycling

Temporary storage must take place in a dry and frost-free environment. The plate dispenser must be kept covered with a suitable covering material to be protected against dust ingress.

The plate dispenser kept in the storage location must be checked for damages and corrosion every 6 months.

NOTE	Condensed water formation
Ensure that there is sufficient ventilation and no large temperature fluctuations in the storage location to avoid condensed water formation.	

Before the appliance is taken back into operation it must be clean and dry.

If the plate dispenser is required to be recycled, all the heating devices (if available) must be removed safely and completely, the recyclable materials must be separated properly and disposed in an environmentally compatible manner according to the Waste Disposal Regulations.

In any case, the local bodies responsible for disposal are to be involved for this purpose.

5 Operation

ATTENTION

Exposed springs



When pressing down the stacking platform manually, the springs are exposed. Reaching into the gaps of the exposed springs may cause hand injuries.

Never press the stacking platform down manually.

Be careful when hooking and unhooking the springs. When adjusting springs on sharp edges, pay particular attention to the ends of the tension springs.

5.1 Arrangement and Function of the Operating Elements

The operating elements are located on the front of the housing of the heated plate dispensers.

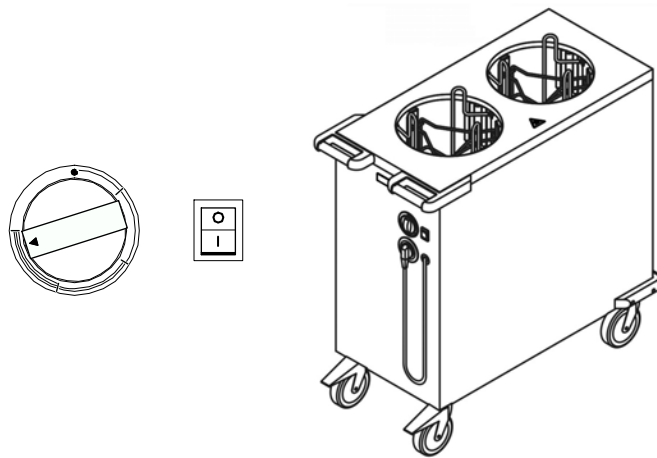

Figure 14 Operating elements

The desired temperature can be set on the thermostat. A continuous adjustment is possible within the 4 power ranges. The On / Off switch of the appliance is arranged next to it. An indicator light integrated into the switch shows, whether the appliance is ready to be operated.

5.2 Plate Dispenser Adjustment

WARNING

Risk of hot surfaces



The internal surfaces of the heated appliances and the base plates can become hot during operation and only cool down slowly in the air.

To adjust the guide basket, allow the appliance to cool down sufficiently with the cover removed.

The adjustments should only be carried out on the appliances which are switched off, disconnected from the power supply and cooled down (room temperature).

Before work starts, it is always necessary to check whether the plate dispenser to be operated is correctly set for the crockery to be used.

The following functions are to be checked separately:

- The vertical guide of the plates, in order to prevent any risk of injury to the operating staff if the crockery guides are set too far apart or too close together.
- The dispensing height, so that the staff cannot suffer injury or become trapped and no breakage of crockery can occur.

Basically, the appliance must be adjusted if at least one of the following crockery parameters alters:

- Diameter
- Height
- Stack height
- Weight.

5.2.1 Crockery guide adjustment

Before loading, the crockery guides must be adjusted to the diameter of the crockery items and fixed in the locking positions provided.

If the crockery guides are set too far apart from each other, the crockery stack can become wedged under the upper plate due to the possible high tilt angles, and can injure the operating staff when released.

If the crockery guides are set too close, the plates can become jammed and can injure people when released suddenly.

Too small crockery items cannot be guided properly and, therefore, should not be used.

Adjustment of crockery guides

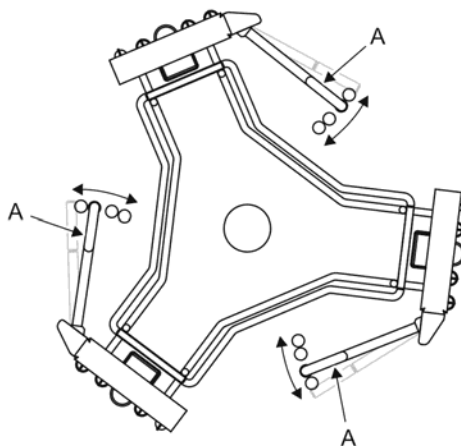

Figure 15 Crockery guides

- Release the crockery guides (A) out of the locking position by lifting them and put them on the outermost position.
- Load a stack of 10 to 12 plates on the guide basket.
- Turn the crockery guides (A) and fix them in the corresponding locking position with respect to the crockery diameter. Check by pressing slightly the crockery stack, whether it can move easily on its guide without rocking.
- All three crockery guides must be fixed in the same locking positions to ensure uniform loading of the stacking platform.
- After the appliance is loaded and before transport begins, the guide rails must be checked again manually to ensure that they are fixed.

Adjust retaining bolts

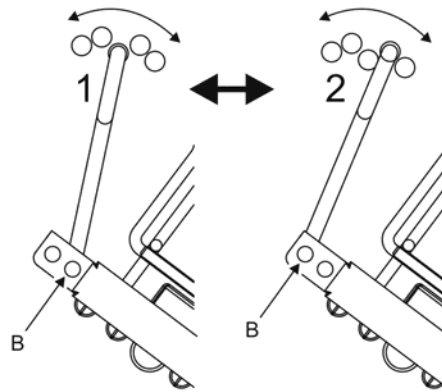



Figure 16 Retaining bolts

- If it is necessary to alternate between the rows of holes in the plate dispenser model 27-33 (except TEUH-2VC27-33), the upper holders of the crockery guides must also be inserted into the available holes. When using TEUH-2VC, the holders of the crockery guide will be fitted respectively on to the other retaining bolts (B).
- Remove the crockery guides in the area of the retaining bolts (B) by pressing them down slightly and fit them onto the other retaining bolts (B).

NOTE	Crockery diameters
	The following crockery diameters can be set with the locking positions provided:
	Plate dispenser Type 19-26: 7.48" / 8.46" / 9.25" / 10.24" (the first row of holes)
	Plate dispenser Type 27-33: 10.63" / 11.81" / 13" (the first row of holes) 11.02" / 12.6" (the second row of holes)

5.2.2 Spring adjustment

ATTENTION	Damage to persons and property due to improper adjustment
	When the dispensing height is exceeded, there is a risk of accident or injury due to tipping of the crockery stack and breakage of dishes. If the level falls below the dispensing height, injuries to the fingers due to squashing can occur when removing dishes. Adjust appropriately the dispensing height by hooking or unhooking the springs. When adjusting springs on sharp edges, pay particular attention to the ends of the tension springs. Act carefully.
ATTENTION	Risk of injury
	Be careful when hooking and unhooking the springs. When adjusting springs on sharp edges, pay particular attention to the ends of the tension springs.
NOTE	Guide basket
	It is not necessary to dismantle the guide basket in order to adjust the springs. It should only be dismantled by specialist staff and, moreover, it is not possible to do this from above without a tool.

Before loading the appliance, the dispensing height must be adjusted to the kind of crockery used. The dispensing height is adjusted by hooking or unhooking tension springs. So long as the same kind of plates is always used, the dispensing height only needs to be set once.

The dispensing height must be adjusted so that over the entire lift the uppermost item of crockery is constantly moved upwards to a uniform dispensing height between 1.6" (4 cm) and 2.4" (6 cm) above the upper rim of the housing.

Step 1 - Checking the spring adjustment

- Load a stack of 15 to 20 items on the guide basket to test the dispensing height.
- Wait for a reaction.

If the dispensing height of the crockery stack is about 1.97" (5 cm) above the upper rim of the appliance, the spring system is adjusted correctly.

If the crockery stack drops down only a little or not at all, the dispensing height must be altered by adjusting the springs.

Step 2 - Altering the spring adjustment

The dispensing height is adjusted by hooking or unhooking tension springs on two attachment bars. The springs are arranged in groups of 5, where 1 to 2 are base springs with higher tension (1) and 4 are adjustable springs (2) with lower tension.

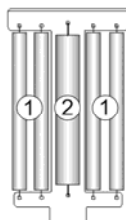

Figure 17 Attachment bar with tension springs

If the dispensing height is too high, adjustable springs must be unhooked.
If the dispensing height is too low, adjustable springs must be added.

Procedure for setting the springs:

- Take the inserted crockery items out of the plate dispenser (if available).
- Hook or unhook adjustable springs uniformly in all groups of springs.
- Preferably unhook the adjustable springs. Always leave the base springs inserted, if possible. Always unhook the springs on the lower attachment bar.

Both steps must be repeated as often as possible, until the dispensing height is in the range from 1.57" (4 cm) to 2.36" (6 cm). So long as the same kind of crockery is always used, the dispensing height only needs to be set once.

NOTE	Arrangement of the springs For guiding the guide basket uniformly and without friction, a symmetrical arrangement of springs between the attachment bars is necessary. A slightly asymmetrical arrangement of springs within an attachment bar does not pose any problem.
NOTE	Spring system Since all the plate dispensers are designed for a maximum crockery load, the available spring system of the appliances is entirely sufficient for all usual market plates. Owing to the base springs with higher tension, the unheated plate dispensers are also unsuitable for plastic items.

5.2.3 Calculating the plate dispenser capacity

The total capacity of a plate dispenser depends on the kinds of crockery loaded and the number of dispensing tubes.

All the leading manufacturers give the necessary data for calculating the intermediate stack height in the following manner:

$$H_z = \frac{(H_n - H_1)}{n-1}$$

H_z : Intermediate stack height
 H_1 : Height of the first crockery item
 H_n : Height of n crockery items
 n : Number of crockery items

Capacity per crockery stack can be calculated together with the stack height H_s of the plate dispenser:

$$K = \frac{(H_s - H_1)}{H_z} + 1$$

K : Items per crockery stack
 H_s : Stack height of the plate dispenser

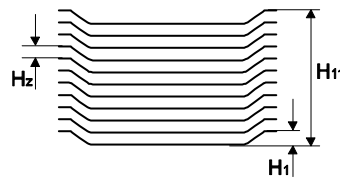

Figure 18 Intermediate stack height H_z of 11 crockery items

Example:

$$H_z = \frac{(140 - 28)}{10} = 11,2 \text{ mm}$$

$H_1 = 1.1''$ (28 mm): Height of the first crockery item
 $H_n = 5.5''$ (140 mm): Height of 11 crockery items
 $t = 11$: Number of crockery items
 $H_s = 24.6''$ (625 mm): Stack height

$$K = \frac{(625 - 28)}{11,2} + 1 = 54$$

So 54 crockery items can be stacked into this dispensing tube.

5.3 Operation

Before the appliance is put into operation it must be clean and dry.

Before work starts, it is always necessary to check whether the plate dispenser to be operated is correctly set for the crockery to be used.

- The vertical guide of the plates must be ensured, in order to prevent any risk of injury to the operating staff if the crockery guides are set too far apart or too close together.
- The correct dispensing height must be ensured, so that the staff cannot suffer injury or become trapped and no breakage of crockery can occur.

Use of the cover

ATTENTION



Risk of injury

If a stack of plates with the covers is too high, do not push it down forcibly. There is a risk of injury, if the locking is released.

NOTE	Use of the cover
<p>The cover ensures effective protection against ingress of dust and condensed water even during relatively long periods of temporary storage. Using the cover in the heated appliances lowers the heat loss upwards and reduces the heating time of the inserted crockery or delays the cooling of pre warmed crockery.</p>	

All the covers are provided with a 3-point locking mechanism.

- Place the cover on to the dispensing tube and lock it by turning it clockwise.
- Open the cover again by turning it anti-clockwise.

When using the plate dispenser with two dispensing tubes, a cover that have been removed previously can be placed on to the second cover of the dispensing tube next to it.

5.3.1 Switching on the appliance

DANGER	Hazardous electrical voltage
	<p>The electrical voltage may be considerably dangerous to limb and life of persons and lead to injuries.</p> <p>Only use the plug connection provided for this. The appliance should not be operated with a damaged lead or other visible damages.</p> <p>All work on the electrical installations should only be carried out by a certified electrician or by authorised specialists under supervision and monitoring of a certified electrician according to the applicable electro-technical regulations.</p>

NOTE	Heated appliances
<p>Some parts of this section relate exclusively to the heated appliances and do not apply to the unheated models.</p>	

- Cover all the dispensing tubes with the covers to avoid heat loss.
- Insert the mains plug into a suitable socket.
- Switch on the appliance with the On / Off switch. The indicator integrated in the switch will light up to show that the appliance is ready for operation.
- Set the desired temperature using the thermostat. A continuous adjustment is possible within the 4 power ranges.

NOTE	Crockery temperature
<p>Depending upon the number and arrangement of the crockery stacks, the required temperature of the crockery with the cover on and an initial crockery temperature of at least 59 °F (15 °C) will be reached after 2 to 3 hours.</p>	

5.3.2 Loading the appliance

NOTE	Loading
<p>Before the crockery items are inserted, the crockery guide and the stack height must be set correctly.</p> <p>Insert the items individually or in small safely manageable stacks.</p>	

NOTE	Warm-keeping items
<p>Metal-coated warm-keeping items filled with wax can also be heated up wrong in the most powerful plate dispenser.</p> <p>The plate dispenser's performance is not sufficient to melt the wax within the metallic sheath. As a result, liquid-to-solid phase transition cannot take place during heat emission, so that the warm-keeping function of the warm-keeping items is drastically reduced.</p>	

Loading crockery

ATTENTION	Breakage of crockery
	<p>The maximum loading height of the crockery baskets must be about 0.1" to 0.2" (3 to 5 mm) below the upper rim, otherwise this can cause breakage of crockery.</p> <p>Do not stack the crockery items into the crockery baskets up to the upper edge of the crockery basket.</p>

- Place the first plates on the centre of the guide basket and lower them slowly.
- Place the further plates precisely onto the plates already positioned in the appliance.
- The maximum filling level is achieved, when the guide basket does not lower anymore while loading further plates.
- If no cover is used, the uppermost plate should not protrude more than 2.36" (6 cm) above the upper rim of the housing.

NOTE	Filling level
<p>A higher filling level is possible in the appliances used with the covers. Depending on the inherent stability of the items, they can be stacked up to the lower rim of the cover. However, in the heated models the crockery items resting above the upper rim of the appliance cannot be heated to the required temperature.</p> <p>The crockery with the cover should not protrude more than 5.1" (13 cm). Even when stationary, the plate dispenser must never be loaded beyond the permitted maximum value of 5.1" (13 cm)'.</p>	

Unloading crockery

WARNING	Risk of burning
	<p>In the heated appliances the crockery temperatures can exceed the permitted maximum temperatures of 149 °F (65 °C) for touchable appliance surfaces.</p> <p>Never reach into the appliance or touch the heating element with the fingers during the operation.</p> <p>Always wear protective gloves when dispensing hot crockery.</p>

- Remove the cover and put it down.
- Take out the plates.
- Put the cover back on.

NOTE

Appliances with cooling slots

The appliances are intended to provide cooled crockery. For this purpose, the loaded appliances must remain in cold stores for several hours. The duration of cooling depends on the initial crockery temperature, the temperature of the cold store and the desired crockery temperature. The appliances must always be free-standing in the room so that optimum air circulation is ensured by free convection within and around the appliances.

5.3.3 Moving the appliance

- Turn off the thermostat.
- Switch off the appliance with the On / Off switch.
- Pull out the mains plug and insert it into the plug park provided.
- Release both brakes.
- Grip the appliance by the push bars and move it to the destination.
- At the destination, apply both brakes in order to secure the appliance against movement.
- Insert the mains plug into a suitable earthed socket.
- Switch on the appliance with the On/Off switch.
- Set the desired temperature using the thermostat.

5.4 Measures at the End of Operation

WARNING

Risk of hot surfaces



The internal surfaces of the appliance and the base plates can become hot during operation and only cool down slowly in the air.

For cleaning, allow the appliance to cool down sufficiently with the cover removed and wear suitable protective gloves.

Mobile appliances



- At the destination, apply both brakes in order to secure the appliance against movement.
- Turn off the thermostat.
- Switch off the appliance with the On / Off switch.
- Pull out the mains plug and insert it into the plug park provided.

Built-in appliances

- Switch off the appliance with the On / Off switch.

6 Fault Detection and Troubleshooting

6.1 Safety Measures

DANGER	Hazardous electrical voltage
	<p>The electrical voltage may be considerably dangerous to limb and life of persons and lead to injuries.</p> <p>Before looking for faults, switch off the appliance at the mains. Pull out the mains plug and insert it into the plug park provided.</p>
ATTENTION	Exposed springs
	<p>When pressing down the stacking platform manually, the springs are exposed. Reaching into the gaps of the exposed springs may cause hand injuries.</p> <p>Never press the stacking platform down manually.</p> <p>Be careful when hooking and unhooking the springs. When adjusting springs on sharp edges, pay particular attention to the ends of the tension springs.</p>

6.2 Notes on Troubleshooting

Please check first whether there is an operating fault. You can eliminate some faults on your own.

Service work should only be carried out by authorised specialists.

Defective components should only be replaced with original parts.

In the event of after-sales service and when ordering spare parts specify the data given in the rating plate.

Inspection and maintenance intervals depend on the use of the appliance. Consult your dealer's after-sales service department.

Regular inspection and maintenance of the appliance prevent disruptions to operation and ensure safety.

6.3 Fault and Action Table

Fault	Possible cause	Action
Appliance does not become warm; indicator light does not come on.	Defective building fuses.	Check fuse and repair, if necessary.
Appliance does not become warm; indicator light does not come on.	Defective On / Off switch.	Switch off the appliance at the mains and have it checked and repaired by authorised specialist staff, if necessary.
Appliance does not become warm; indicator light does not come on.	Defective lead or mains plug	Switch off the appliance at the mains and have it checked and repaired by authorised specialist staff, if necessary.
Appliance does not become warm; indicator light is on.	Thermostat is defective.	Take the appliance out of operation and have it checked and repaired by authorised specialist staff, if necessary.
Appliance becomes warm; indicator light does not come on.	Defective indicator light.	Take the appliance out of operation and have it checked and repaired by authorised specialist staff, if necessary.

Fault	Possible cause	Action
Appliance becomes warm; indicator light does not come on.	Defective On / Off switch.	Take the appliance out of operation and have it checked and repaired by authorised specialist staff, if necessary.
Guide basket does not move plates upwards to the dispensing height even with a low load	Spring breakage	Replace defective springs by new ones
Brakes do not have any locking action	Brakes are worn	Either renew the locking brakes or replace the defective casters

7 Cleaning and Care

7.1 Safety Measures

DANGER

Hazardous electrical voltage



The electrical voltage may be considerably dangerous to limb and life of persons and lead to injuries.

Before cleaning, switch off the appliance at the mains. Pull out the mains plug and insert it into the plug park provided.

WARNING

Risk of hot surfaces



The internal surfaces of the appliance and the base plates can become hot during operation and only cool down slowly in the air.

For cleaning, allow the appliance to cool down with the cover removed and wear suitable protective gloves.

ATTENTION

Exposed springs



When pressing down the stacking platform manually, the springs are exposed. Reaching into the gaps of the exposed springs may cause hand injuries.

Never press the stacking platform down manually.

Be careful when hooking and unhooking the springs. When adjusting springs on sharp edges, pay particular attention to the ends of the tension springs.

ATTENTION

Do not clean with running water



The appliance should not be cleaned with running water, steam-jet or high-pressure washers. The appliance must be taken out of operation and switched off at the mains beforehand in any area where steam-jet or high-pressure washers are to be used.

7.2 Hygiene Measures

The correct behaviour of the operating staff is decisive for optimal hygiene.

All persons must be informed about the locally valid hygiene regulations, observe them and comply with them.

Stick a waterproof plaster to cover wounds on the hands and arms.

Never sneeze or cough on clean crockery.

7.3 Cleaning and Care

The appliance must be cleaned dry daily or wiped with a damp cloth. Dry well the appliance after carrying out wet cleaning, in order to prevent the development of mould, uncontrolled growth of germs and bacteria and, consequently, contamination of the crockery.

All the plate dispensers (except TEUH-2/VC) have a base outlet located below the dispensing tubes that is provided for the removal of broken crockery or other objects, which have accidentally fallen down into the appliance. The objects that have fallen down into the enclosed dispenser can be removed by means of a vacuum cleaner or gripping tongs.

The plastic covers can be cleaned manually with a damp cloth. In the case of solid impurities, appliances can also be cleaned in a commercial dishwasher. Washing and rinsing agents suitable for polycarbonate should be used.

7.4 Special Care Instructions

The resistance to corrosion of stainless steels is based on a passive layer which is formed on the surface when oxygen is admitted. The oxygen in the air is sufficient for the formation of the passive layer, so that faults or damage to the passive layer can be remedied again automatically by mechanical action.

The passive layer develops or reforms more quickly when the steel comes into contact with flowing water containing oxygen. The passive layer can be chemically damaged or disrupted by agents having a reducing (oxygen-consuming) action when the steel comes into contact with them in concentrated form or at high temperatures.

Such aggressive substances are for example:

- substances containing salt and sulphur
- chlorides (salts)
- seasoning concentrates (e.g. mustard, vinegar essence, seasoning cubes, saline solution)

Further damages can occur due to:

- extraneous rust (e.g. from other components, tools or rust film)
- iron particles (e.g. grinding dust)
- contact with non-ferrous metals (element formation)
- lack of oxygen (e.g. no admission of air, low-oxygen water).

General working principles for the handling of appliances made of "refined stainless steel":

- Always keep the surface of appliances made from stainless steel clean and accessible to the air.
- Use cleaning agents suitable for stainless steel. No bleaching and chloride-containing cleaning agents should be used.
- Remove layers of lime scale, grease, starch and egg-white daily by cleaning. Corrosion can occur underneath these layers due to lack of air admission.
- After each cleaning operation remove all cleaning agent residues by rinsing thoroughly with copious fresh water. Afterwards, the surface should be thoroughly dried.
- Do not bring parts made from stainless steel into contact with concentrated acids, seasonings, salts etc. for longer than is absolutely necessary. Acid fumes which generate during cleaning of tiles also promote the corrosion of "refined stainless steel".
- Avoid damaging the surface of the stainless steel, particularly by metals other than stainless steel.
- Residues of extraneous metals produce extremely small amounts of chemical elements which can cause corrosion. In any case, contact with iron and steel should be avoided because that leads to extraneous rust. If stainless steel comes into contact with iron (steel wool, steel particles from pipes, water containing iron), this can be a trigger for corrosion. Therefore, for mechanical cleaning use exclusively refined steel wool or brushes with natural, plastics or refined steel bristles. Steel wool or brushes with unalloyed steel lead to extraneous rust due to abrasion.

8 Spare Parts and Accessories

8.1 Introduction

Service work should only be carried out by authorised specialists.

Defective components should only be replaced with original parts.

In the event of after-sales service and when ordering spare parts, always specify the data and corresponding part number indicated on the rating plate.

8.2 Spare Parts and Accessories List

TE-2/V 19-26 | TE-2/VK 19-26

014000402	Swivel caster	Ø 125 with breaks plate, bearing, plastic	incl. 4 nuts
014000401	Swivel caster	Ø 125 plate, bearing, plastic	incl. 4 nuts
0191176895	Push bar	left+right PP 192/180/30 black	incl. fixing material
014002110	Corner bumpers	complete set	(package contents 4 piece)
014040101	Tension spring	stainless steel 10gr Ø1.5/Ø20/146 set	(package contents 5 piece)
014040164	Tension spring	stainless steel 5gr Ø1.0/Ø12/146 set	(package contents 5 piece)
4318000	Guide basket	steel 336/293/130 cpl	
4322000	Cover	PC Ø310/103/3 transp	
91092186	Adjustment bracket	Ø7.8/805/114 cpl	

TE-2/V 27-33

014000402	Swivel caster	Ø 125 with breaks plate, bearing, plastic	incl. 4 nuts
014000401	Swivel caster	Ø 125 plate, bearing, plastic	incl. 4 nuts
0191176895	Push bar	left+right PP 192/180/30 black	incl. fixing material
014002110	Corner bumpers	complete set	(package contents 4 piece)
014040101	Tension spring	stainless steel 10gr Ø1.5/Ø20/146 set	(package contents 5 piece)
014040164	Tension spring	stainless steel 5gr Ø1.0/Ø12/146 set	(package contents 5 piece)
91009066	Guide basket	steel 345/345/130 coat.	
91004816	Cover	PC Ø380/203/3 transp	
91092186	Adjustment bracket	Ø 7.8/805/114 cpl	

TEH-1/V 19-26 | TEH-2/V 19-26

14000402	Swivel caster	Ø 125 with breaks plate, bearing, plastic	incl. 4 nuts
014000401	Swivel caster	Ø 125 plate, bearing, plastic	incl. 4 nuts
0191176895	Push bar	left+right PP 192/180/30 black	incl. fixing material
014002110	Corner bumpers	complete set	(package contents 4 piece)

014040101	Tension spring	stainless steel 10gr Ø1.5/Ø20/146 set	(package contents 5 piece)
014040164	Tension spring	stainless steel 5gr Ø1.0/Ø12/146 set	(package contents 5 piece)
4318000	Guide basket	steel 336/293/130 cpl	
4322000	Cover	PC Ø310/103/3 transp	
014040011-01	Thermostat	30-115° C	
4001081	Lead	Wend.H05BQ-F 3G1,0/1600 WS- DE FH	
4040068	Heating	stainless st. 230V 900W 8.5/1420	
0191148605	Dummy socket	Ø75/43 sw cpl	
014001300	On / Off switch	w. frame, spray h..	
014002170-01	Thermostat	switching module, complete	
91095077	Limiter	temp. protection 90°C 2Ö	
0163655	Cable gland	with tension relief set	
91257963	Cable set	TEH	
91092186	Adjustment bracket	Ø7.8/805/114 cpl	

TEH-1/V 27-33

014000402	Swivel caster	Ø 125 with breaks plate, bearing, plastic	incl. 4 nuts
014000401	Swivel caster	Ø 125 plate, bearing, plastic	incl. 4 nuts
0191176895	Push bar	left+right PP 192/180/30 black	incl. fixing material
014002110	Corner bumpers	complete set	(package contents 4 piece)
4001081	Lead	Wend.H05BQ-F 3G1,0/1600 WS- DE FH	
014002170-01	Thermostat	switching module, complete	
4040068	Heating	stainless st. 230V 900W 8.5/1420	
014040101	Tension spring	stainless steel 10gr Ø1.5/Ø20/146 set	(package contents 5 piece)
014040164	Tension spring	stainless steel 5gr Ø1.0/Ø12/146 set	(package contents 5 piece)
91009066	Guide basket	steel 345/345/130 coat.	
91004816	Cover	PC Ø380/203/3 transp	
014040011-01	Thermostat	30-115° C	
014001300	On / Off switch	w. frame, spray h..	
91095077	Limiter	temp. protection 90°C 2Ö	
0163655	Cable gland	with tension relief set	
91257963	Cable set	TEH	
91092186	Adjustment bracket	Ø7.8/805/114 cpl	

TEH-2/V 27-33

014000402	Swivel caster	Ø 125 with breaks plate, bearing, plastic	incl. 4 nuts
014000401	Swivel caster	Ø 125 plate, bearing, plastic	incl. 4 nuts
0191176895	Push bar	left+right PP 192/180/30 black	incl. fixing material
014002110	Corner bumpers	complete set	(package contents 4 piece)
4001081	Lead	Wend.H05BQ-F 3G1,0/1600 WS-DE FH	
014002170-01	Thermostat	switching module, complete	
4040213	Heating	stainless st. 230V 1500W 8.5/2627 UL	
014040101	Tension spring	stainless steel 10gr Ø1.5/Ø20/146 set	(package contents 5 piece)
014040164	Tension spring	stainless steel 5gr Ø1.0/Ø12/146 set	(package contents 5 piece)
91009066	Guide basket	steel 345/345/130 coat.	
91004816	Cover	PC Ø380/203/3 transp	
014040011-01	Thermostat	30-115° C	
014001300	On / Off switch	w. frame, spray h.	
91095077	Limiter	temp. protection 90°C 2Ö	
0163655	Cable gland	with tension relief set	
91257963	Cable set	TEH	
91092186	Adjustment bracket	Ø 7.8/805/114 cpl	

TEUH-2/VS 19-26

014000402	Swivel caster	Ø 125 with breaks plate, bearing, plastic	incl. 4 nuts
014000401	Swivel caster	Ø 125 plate, bearing, plastic	incl. 4 nuts
0191176895	Push bar	left+right PP 192/180/30 black	incl. fixing material
014002110	Corner bumpers	complete set	(package contents 4 piece)
4001081	Lead	Wend.H05BQ-F 3G1,0/1600 WS-DE FH	
014002170-01	Thermostat	switching module, complete	
4040213	Heating	stainless st. 230V 1500W 8.5/2627 UL	
014040101	Tension spring	stainless steel 10gr Ø1.5/Ø20/146 set	(package contents 5 piece)
014040164	Tension spring	stainless steel 5gr Ø1.0/Ø12/146 set	(package contents 5 piece)
4318000	Guide basket	steel 336/293/130 cpl	
4322000	Cover	PC Ø310/103/3 transp	
0163655	Cable gland	with tension relief set	
91095077	Limiter	temp. protection 90°C 2Ö	
014040011-01	Thermostat	30-115° C	
014001300	On / Off switch	w. frame, spray h.	

91146181	Fan	radial Ø120 240V 60Hz 38W UL	
91141227-1	Cable set	TEUH/ VS	
91092186	Adjustment bracket	Ø 7.8/805/114 cpl	

TEUH-2/VS 27-33

014000402	Swivel caster	Ø 125 with breaks plate, bearing, plastic	incl. 4 nuts
014000401	Swivel caster	Ø 125 plate, bearing, plastic	incl. 4 nuts
0191176895	Push bar	left+right PP 192/180/30 black	incl. fixing material
014002110	Corner bumpers	complete set	(package contents 4 piece)
4001081	Lead	Wend.H05BQ-F 3G1,0/1600 WS-DE FH	
014002170-01	Thermostat	switching module, complete	
91211252	Heating	stainless st. 230V 1500W 8.5/2825 UL	
014040101	Tension spring	stainless steel 10gr Ø1.5/Ø20/146 set	(package contents 5 piece)
014040164	Tension spring	stainless steel 5gr Ø1.0/Ø12/146 set	(package contents 5 piece)
91009066	Guide basket	steel 345/345/130 coat.	
91004816	Cover	PC Ø380/203/3 transp	
0163655	Cable gland	with tension relief set	
91095077	Limiter	temp. protection 90°C 2Ö	
014040011-01	Thermostat	30-115° C	
014001300	On / Off switch	w. frame, spray h.	
91146181	Fan	radial Ø120 240V 60Hz 38W UL	
91141227-1	Cable set	TEUH/ VS	
91092186	Adjustment bracket	Ø 7.8/805/114 cpl	

TEUH-2/VC 19-26

014000402	Swivel caster	Ø 125 with breaks plate, bearing, plastic	incl. 4 nuts
014000401	Swivel caster	Ø 125 plate, bearing, plastic	incl. 4 nuts
0191176895	Push bar	left+right PP 192/180/30 black	incl. fixing material
014002110	Corner bumpers	complete set	(package contents 4 piece)
91082883	Lead	Wend.H07BQ-F 3G1,5/1600 WS-	
014002170-01	Thermostat	switching module, complete	
4041047-03	Heating	stainless st. 230V 2000W 6.5/1313 UL	
014040101	Tension spring	stainless steel 10gr Ø1.5/Ø20/146 set	(package contents 5 piece)
014040164	Tension spring	stainless steel 5gr Ø1.0/Ø12/146 set	(package contents 5 piece)
4318002	Guide basket	stainless st. Ø230-260/130 cpl	
4322002	Cover	PC Ø310/103/3 transp	
0163655	Cable gland	with tension relief set	

91095077	Limiter	temp. protection 90°C 2Ö	
014040228-01	Thermostat	30-130°C set	(package contents 2 piece)
014001300	On / Off switch	w. frame, spray h.	
014001013	Hot air fan	240V/50HzR2K150AC037	
4328004	Cable set	TEUH-2/ VC 19-26	
4319003	Crockery guide	stainless st. Ø8/715/125 epol	

EBR/V 19-26

014040101	Tension spring	stainless steel 10gr Ø1.5/Ø20/146 set	(package contents 5 piece)
014040164	Tension spring	stainless steel 5gr Ø1.0/Ø12/146 set	(package contents 5 piece)
4318000	Guide basket	steel 336/293/130 cpl	
4322000	Cover	PC Ø310/103/3 transp	
91002254	Crockery guide	steel 696/116/16 cpl	

EBR/V 27-33

014040101	Tension spring	stainless steel 10gr Ø1.5/Ø20/146 set	(package contents 5 piece)
014040164	Tension spring	stainless steel 5gr Ø1.0/Ø12/146 set	(package contents 5 piece)
91009066	Guide basket	steel 345/345/130 coat.	
91004816	Cover	PC Ø380/203/3 transp	
91002254	Crockery guide	steel 696/116/16 cpl	

EBRH/V 19-26

014040101	Tension spring	stainless steel 10gr Ø1.5/Ø20/146 set	(package contents 5 piece)
014040164	Tension spring	stainless steel 5gr Ø1.0/Ø12/146 set	(package contents 5 piece)
4318000	Guide basket	steel 336/293/130 cpl	
4322000	Cover	PC Ø310/103/3 transp	
4128901	Lead	conn.installation stacker cpl	
91010879	Heating	stainless st. 230V 200W 8.5/836 UL	
014510022	Appliance plug	STA 6,3 161.5 set	(package contents 5 piece)
91095077	Limiter	temp. protection 90°C 2Ö	
4001214	Thermostat	20-85°C, 1S Kl. 870	
91025444-1	Cable set	EBRH-1/V	
91002254	Crockery guide	steel 696/116/16 cpl	

EBRH/V 27-33

014040101	Tension spring	stainless steel 10gr Ø1.5/Ø20/146 set	(package contents 5 piece)
014040164	Tension spring	stainless steel 5gr Ø1.0/Ø12/146 set	(package contents 5 piece)
91009066	Guide basket	steel 345/345/130 coat.	
91004816	Cover	PC Ø380/203/3 transp	
4128901	Lead	conn. installation stacker cpl	
91010879	Heating	stainless st. 230V 200W 8.5/836 UL	
014510022	Appliance plug	STA 6,3 161.5 set	(package contents 5 piece)
91095077	Limiter	temp. protection 90°C 2Ö	
4001214	Thermostat	20-85°C, 1S Kl. 870	
91025444-1	Cable set	EBRH-1/V	
91002254	Crockery guide	steel 696/116/16 cpl	

EBRH-2/V 19-26

014040101	Tension spring	stainless steel 10gr Ø1.5/Ø20/146 set	(package contents 5 piece)
014040164	Tension spring	stainless steel 5gr Ø1.0/Ø12/146 set	(package contents 5 piece)
91008095	Guide basket	steel 318/296/121 coat.	
4322000	Cover	PC Ø310/103/3 transp	
4128901	Lead	conn. Installation stacker cpl	
4510023	Heating	stainless st. 230V 500W 8.5/986 UL	
014510022	Appliance plug	STA 6,3 161.5 set	(package contents 5 piece)
91095077	Limiter	temp. protection 90°C 2Ö	
4040011-01	Thermostat	30-115°C 1S cl.870 UL	
91008379-1	Cable set	EBRH-2/V	
91002254	Crockery guide	steel 696/116/16 cpl	

The following types of plug can be used with the plate dispensers:

- 2-pole Schuko® plug (standard)
- 3-pole British mains plug in accordance with BS 1363 A for Great Britain and Hong Kong
- 3-pole Swiss mains plug of type 12 - 10 A

9 Annex

9.1 EC Declaration of Conformity



CE Konformitätserklärung

Declaration of CE-Conformity | Déclaration de conformité CE

Gegenstand | Object | Objet
Tellerstapler | plate dispenser | Chariot niveau constant assiettes

Artikelgruppe | Article category | Groupe d'articles
24020

Typ | Type | Type
TE-2 | TE-2 | TE-2

Es wird bescheinigt, dass das/die zuvor näher beschriebene/n Produkt/e der/den im Folgenden aufgelisteten EU-Richtlinie/n entspricht/entsprechen:
2006/42/EG
Darüber hinaus wurden folgende harmonisierte Normen angewandt:
EN ISO 12100:2010

It is certified that the product/s described in detail before, conform/s to the requirements of the European Union directive/s listed in the following:
2006/42/EC
Furthermore, the following harmonised standards have been applied:
EN ISO 12100:2010

Il est certifié que le/s produit/s décrit/s en détail ci-dessus, correspond/ent aux directive/s de l'UE énuméré/és dans ce qui suit:
2006/42/CE
En outre, les normes harmonisées suivantes ont été appliquées:
EN ISO 12100:2010

Coesfeld, 10.04.2013

Helmut Schumacher Vorname, Nachname	Geschäftsführung Position	Unterschrift
Jürgen Gottwald Vorname, Nachname	Leiter Normenstelle Position	Unterschrift
Dokumentationsbevollmächtigter Jürgen Gottwald	HUPFER® Metallwerke GmbH & Co. KG	Info@hupfer.de

Diese Konformitätserklärung ist eine original Konformitätserklärung in deutscher Sprache und kann gleichlautende Übersetzungen in weiteren EU-Sprachen enthalten. This declaration of conformity is an original declaration of conformity in the German language and can contain identical translations in the other EU languages. Cette déclaration de conformité est une déclaration de conformité originale en langue allemande et peut contenir des traductions conformes en d'autres langues de l'UE.

HUPFER® Metallwerke GmbH & Co KG
Dieselstraße 20 | 48653 Coesfeld | Deutschland | +49 2541 805-0 | info@hupfer.de

CE Konformitätserklärung

Declaration of CE-Conformity | Déclaration de conformité CE



Gegenstand | Object | Objet
Tellerstapler | plate dispenser | Chariot niveau constant assiettes

Artikelgruppe | Article category | Groupe d'articles
24010, 24030

Typ | Type | Type
TEH, -UH, EBRH | TEH, -UH, EBRH | TEH, -UH, EBRH

Es wird bescheinigt, dass das/die zuvor näher beschriebene/n Produkt/e der/den im Folgenden aufgelisteten EU-Richtlinie/n entspricht/entsprechen:

2006/42/EG, 2006/95/EG

Darüber hinaus wurden folgende harmonisierte Normen angewandt:

EN ISO 12100:2010, EN 60335-1, EN 60335-2-49, EN 61140

Im Übrigen wird bescheinigt, dass das/die Produkt/e weder Störungsquellen noch störungsanfällige Bauteile im Sinne der EMV-Richtlinie enthält/enthalten.

It is certified that the product/s described in detail before, conform/s to the requirements of the European Union directive/s listed in the following:

2006/42/EC, 2006/95/EC

Furthermore, the following harmonised standards have been applied:

EN ISO 12100:2010, EN 60335-1, EN 60335-2-49, EN 61140

Incidentally, it is certified that the product/s contain/s neither sources of disturbance nor components liable to disturbances according to the EMC directive.

Il est certifié que le/s produit/s décrit/s en détail ci-dessus, correspond/ent aux directive/s de l'UE énuméré/es dans ce qui suit:

2006/42/CE, 2006/95/CE

En outre, les normes harmonisées suivantes ont été appliquées:

EN ISO 12100:2010, EN 60335-1, EN 60335-2-49, EN 61140

Il est certifié aussi, que le/s produit/s ne contient/contiennent ni des sources de perturbation ni des éléments de construction exposés à des perturbations correspondant aux directives de l'AECM.

Coesfeld, 10.04.2013

Helmut Schumacher Vorname, Nachname	Geschäftsführung Position	Unterschrift
---	-------------------------------------	--------------

Jürgen Gottwald Vorname, Nachname	Leiter Normenstelle Position	Unterschrift
---	--	--------------

Dokumentationsbevollmächtigter Jürgen Gottwald	HUPFER® Metallwerke GmbH & Co. KG	info@hupfer.de
--	---	----------------

Diese Konformitätserklärung ist eine original Konformitätserklärung in deutscher Sprache und kann gleichlautende Übersetzungen in weiteren EU-Sprachen enthalten. This declaration of conformity is an original declaration of conformity in the German language and can contain identical translations in the other EU languages. Cette déclaration de conformité est une déclaration de conformité originale en langue allemande et peut contenir des traductions conformes en d'autres langues de l'UE.

HUPFER® Metallwerke GmbH & Co KG
Dieselstraße 20 | 48653 Coesfeld | Deutschland | +49 2541 805-0 | info@hupfer.de

