

## Operating Instructions

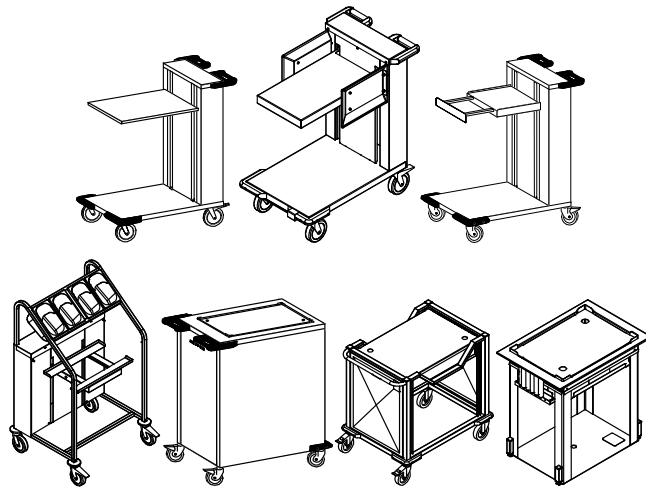

## Tray dispenser

OTA/47-36 | OTA/53-37 | OTA/58-33 | OTA/53-37 S | OTA/U-  
BW | OTA-E/BA-4xGN | TAG-1/53-37 | TA-2/53-37 | EBS-T/53-37

# 1 Introduction

---

## 1.1 Appliance Information

---

Appliance designation	Tray dispenser
Appliance type/ -s	OTA/47–36   OTA/53–37   OTA/58-33   OTA/53–37 S   OTA/U-BW   OTA-E/BA-4xGN   TAG-1/53-37   TA-2/53- 37   EBS-T/53-37
Year of manufacture	2013
Manufacturer	HUPFER® Metallwerke GmbH & Co. KG Dieselstraße 20 48653 Coesfeld  P.O. Box 1463 48634 Coesfeld  ☎ +49 2541 805-0 📠 +49 2541 805-111  <a href="http://www.hupfer.de">www.hupfer.de</a> <a href="mailto:info@hupfer.de">info@hupfer.de</a>

Read these operating instructions thoroughly to ensure safe operation and avoid any damages before the first operation.

Ensure that sources of danger and possible faulty operations have been pointed out to the operating staff.

### Subject to modifications

The products covered by these operating instructions have been developed taking into consideration the requirements of the market and the latest technology. HUPFER® reserves the right to modify the products and related technical documentation in the interests of technical progress. The data and weights as well as the description of performance and functions assured in the order confirmation as binding are always decisive.

**This manual s a translation of the original edition.**

**Manual edition**  
4330041\_A2

## 1.2 Table of Contents

---

<b>1</b>	<b>Introduction</b>	<b>2</b>
1.1	Appliance Information	2
1.2	Table of Contents	3
1.3	List of Abbreviations	5
1.4	Definitions of Terms	6
1.5	Orientation Guide	7
1.6	Notes on Use of Manual	8
1.6.1	Notes on the Manual Structure	8
1.6.2	Notes and their Illustrations used in the Chapters	8
<b>2</b>	<b>Safety Instructions</b>	<b>9</b>
2.1	Introduction	9
2.2	Warning Symbols Used	9
2.3	Safety Instructions for Appliance Safety	9
2.3.1	Special safety instructions for mobile tray dispensers	10
2.3.2	Special safety instructions for open tray dispensers	10
2.3.3	Special safety instructions for closed tray dispensers	10
2.4	Safety Instructions for Cleaning and Care	10
2.5	Safety Instructions for Troubleshooting	10
<b>3</b>	<b>Description and Technical Data</b>	<b>11</b>
3.1	Performance Description	11
3.2	Proper Use	11
3.3	Improper Use	11
3.4	Appliance Description	12
3.4.1	View of the appliance	12
3.4.2	Appliance Description	14
3.4.3	Optional special accessories	14
3.5	Technical Data	14
3.6	Rating Plate	17
<b>4</b>	<b>Transport, Commissioning, Assembly and Decommissioning</b>	<b>18</b>
4.1	Transport	18
4.2	Assembly (EBS-T/53-37 only)	18
4.3	Putting into Operation	19
4.4	Storage and Recycling	20
<b>5</b>	<b>Operation</b>	<b>21</b>
5.1	Adjustment of the closed Tray Dispensers	21
5.1.1	Adjusting springs	21
5.2	Adjustment of the open Tray Dispensers	23
5.2.1	Adjust the model OTA/S	23
5.2.2	Adjustments OTA/U-BW	24
5.2.3	Adjusting springs	26

5.3	Calculating the Capacity for Tray Dispensers	28
5.4	Operation	29
<b>6</b>	<b>Troubleshooting and Repair</b>	<b>30</b>
6.1	Safety Measures	30
6.2	Notes on Troubleshooting	30
6.3	Fault and Action Table	30
<b>7</b>	<b>Cleaning and Care</b>	<b>31</b>
7.1	Safety Measures	31
7.2	Hygiene Measures	31
7.3	Cleaning and Care	31
7.4	Special Care Instructions	31
<b>8</b>	<b>Spare Parts and Accessories</b>	<b>33</b>
8.1	Introduction	33
8.2	Spare Parts and Accessories List	33
<b>9</b>	<b>Annex</b>	<b>35</b>
9.1	EC Declaration of Conformity	35

## 1.3 List of Abbreviations

Abbreviation	Definition																																				
BGR	Employer's Liability Insurance Association																																				
BGV	Regulation of the Professional Association																																				
CE	Communauté Européenne European Community																																				
DIN	Deutsches Institut für Normung German Institute for Standardisation, technical regulations and technical specifications																																				
EC	European Community European Union																																				
EN	European Standard Harmonised standard for the EU market																																				
E/V	Spare and wearing part																																				
IP	<p>International Protection. The abbreviation IP and a further two-digit index specify the protection class of a housing.</p> <p>The first digit: Protection against ingress of solid foreign objects      The second digit: Protection against ingress of water</p> <table border="1"> <tbody> <tr> <td>0</td> <td>No protection against contact, no protection against ingress of solid foreign objects</td> <td>0</td> <td>No protection against ingress of water</td> </tr> <tr> <td>1</td> <td>Protection against contact with any large surface of the body such as the hand, protection against ingress of foreign objects <math>\varnothing &gt; 1.96''</math> (50 mm)</td> <td>1</td> <td>Protection against dripping water (vertically falling drops)</td> </tr> <tr> <td>2</td> <td>Protection against contact with the fingers, protection against ingress of foreign objects <math>\varnothing &gt; 0.5''</math> (12 mm)</td> <td>2</td> <td>Protection against dripping water (at any angle up to 15° from the vertical)</td> </tr> <tr> <td>3</td> <td>Protection against contact with tools, thick wires or similar objects of <math>\varnothing &gt; 0.1''</math> (2.5 mm) protection against foreign objects <math>\varnothing &gt; 0.1''</math> (2.5 mm)</td> <td>3</td> <td>Protection against water drips at any angle up to 60° from the vertical</td> </tr> <tr> <td>4</td> <td>Protection against contact with tools, thick wires or similar objects of <math>\varnothing &gt; 0.4''</math> (1 mm) protection against foreign objects <math>\varnothing &gt; 0.4''</math> (1 mm)</td> <td>4</td> <td>Protection against water splashing from any direction</td> </tr> <tr> <td>5</td> <td>Protection against contact, protection against dust deposits inside</td> <td>5</td> <td>Protection against water jets (projected by a nozzle) at any angle</td> </tr> <tr> <td>6</td> <td>Complete protection against contact, protection against ingress of dust</td> <td>6</td> <td>Protection against rough sea or strong water jets (flood protection)</td> </tr> <tr> <td></td> <td></td> <td>7</td> <td>Protection against ingress of water during temporary immersion</td> </tr> <tr> <td></td> <td></td> <td>8</td> <td>Protection against pressurised water during continuous immersion</td> </tr> </tbody> </table>	0	No protection against contact, no protection against ingress of solid foreign objects	0	No protection against ingress of water	1	Protection against contact with any large surface of the body such as the hand, protection against ingress of foreign objects $\varnothing > 1.96''$ (50 mm)	1	Protection against dripping water (vertically falling drops)	2	Protection against contact with the fingers, protection against ingress of foreign objects $\varnothing > 0.5''$ (12 mm)	2	Protection against dripping water (at any angle up to 15° from the vertical)	3	Protection against contact with tools, thick wires or similar objects of $\varnothing > 0.1''$ (2.5 mm) protection against foreign objects $\varnothing > 0.1''$ (2.5 mm)	3	Protection against water drips at any angle up to 60° from the vertical	4	Protection against contact with tools, thick wires or similar objects of $\varnothing > 0.4''$ (1 mm) protection against foreign objects $\varnothing > 0.4''$ (1 mm)	4	Protection against water splashing from any direction	5	Protection against contact, protection against dust deposits inside	5	Protection against water jets (projected by a nozzle) at any angle	6	Complete protection against contact, protection against ingress of dust	6	Protection against rough sea or strong water jets (flood protection)			7	Protection against ingress of water during temporary immersion			8	Protection against pressurised water during continuous immersion
0	No protection against contact, no protection against ingress of solid foreign objects	0	No protection against ingress of water																																		
1	Protection against contact with any large surface of the body such as the hand, protection against ingress of foreign objects $\varnothing > 1.96''$ (50 mm)	1	Protection against dripping water (vertically falling drops)																																		
2	Protection against contact with the fingers, protection against ingress of foreign objects $\varnothing > 0.5''$ (12 mm)	2	Protection against dripping water (at any angle up to 15° from the vertical)																																		
3	Protection against contact with tools, thick wires or similar objects of $\varnothing > 0.1''$ (2.5 mm) protection against foreign objects $\varnothing > 0.1''$ (2.5 mm)	3	Protection against water drips at any angle up to 60° from the vertical																																		
4	Protection against contact with tools, thick wires or similar objects of $\varnothing > 0.4''$ (1 mm) protection against foreign objects $\varnothing > 0.4''$ (1 mm)	4	Protection against water splashing from any direction																																		
5	Protection against contact, protection against dust deposits inside	5	Protection against water jets (projected by a nozzle) at any angle																																		
6	Complete protection against contact, protection against ingress of dust	6	Protection against rough sea or strong water jets (flood protection)																																		
		7	Protection against ingress of water during temporary immersion																																		
		8	Protection against pressurised water during continuous immersion																																		
LED	Light Emitting Diode Light diode																																				
LMHV	Regulation on the hygiene of foodstuffs																																				
RCE	Residual current device (RCD) The use of the English term RCD (Residual Current Device) is customary in industrial standards in the EU.																																				

## 1.4 Definitions of Terms

Term	Definition
Authorised specialist	An authorised specialist is a specialist that has been trained by the manufacturer, an authorised service dealer or a company assigned by the manufacturer.
Cover	A bell-shaped cover for keeping food warm on plates and dishes.
Cook&Chill Kitchens	"Cook and Chill": Kitchens where warm food after being cooked is chilled as quickly as possible.
Cook&Serve Kitchens	"Cook and Serve": Kitchens where warm food is served immediately after being cooked or kept warm until it is consumed.
Element formation	Also: contact corrosion. Occurs when different noble metals are in close contact with each other. This happens when a corrosive medium is between both metals, as for example water or even air humidity.
EN tray	A European standard tray is a tray with a standard size. EN 1/1 corresponds to 20.9x14.6" (530x370 mm), EN 1/2 corresponds to 14.6x10.4" (370x265 mm).
Specialist	A specialist is a person who can evaluate work assigned and can individually recognise any possible dangers due to professional training, specialist knowledge and experience as well as knowledge of the respective guidelines.
Gastronorm	Gastronorm is a measurement system applied worldwide, for instance, in food processing plants or large-scale kitchens. The use of standardised sizes makes it possible to exchange food pans. The basic size of the Gastronorm (GN) 1/1 is 20.9x12.8" (530x325mm). Items are available in different depths.
H1	Hygienic standard (NSF/USDA) for lubricants that are suitable for incidental and technically unavoidable contact with foodstuffs
HACCP	The HACCP concept is a preventive system that should ensure the safety of foods and consumers..
GN tray	A Gastronorm standard tray is a standard-size tray. GN 1/1 corresponds to 20.9x12.8" (530x325 mm), GN 1/2 corresponds to 12.8x10.4" (325x265 mm).
Lift	A movement such as the vertical movement of the stacking platform from bottom to top.
Control	Compare with certain conditions and/or characteristics such as damage, leaks, filling levels, heat.
Convection	Physical properties or mass transfer (e.g. heat or cold) through currents in gases and liquids.
Corrosion	The chemical reaction of a metallic material with its surroundings, e.g. rust.
LMHV	Regulation on the Hygiene of Foodstuffs Regulation on the requirements concerning hygiene when producing, handling and placing food on the market
Machine safety	The term of machine safety means all the measures used to avert injury to persons. The basis for this are national as well as EC-wide valid directives and laws for protecting users of technical devices and systems.
Passive layer	A non-metallic protective layer on a metallic material that prevents or slows down material corrosion.
Check	Compare with certain values such as weight, torque, content, temperature.
Qualified person, qualified personnel	Qualified personnel are persons who due to their professional training, experience and instruction as well as their knowledge of the respective standards, guidelines, accident prevention regulations and operating conditions have been authorised by a person responsible for system safety to carry out required activities and can recognise and prevent any possible danger (definition of specialists according to IEC 364).
Schuko®	The abbreviation of the German term "Protective contact" that indicates a system of domestic plugs and sockets equipped with protective earthed contacts used in most of Europe.
Instructed persons	An instructed person is a person who has been instructed on the possible risks resulting from improper behaviour when carrying out the assigned task as well as on the necessary protective equipment and protective measures and trained for this task if necessary.

## 1.5 Orientation Guide

---

### **The front**

"Front" refers to the operating side.

Push bars are installed on the mobile tray dispensers to move the tray dispenser.

From the front of the cutlery and tray dispensers, the silverware attachments are available.

The side of the built-in appliance named as "front" means the side, at which the staff operates the appliance.

### **The rear**

"Rear" refers to the opposite side of the front side (the front).

### **The right**

"Right" refers to the right hand side when viewed from the front side (front).

### **The left**

"Left" refers to the left hand side when viewed from the front side (front).



## 1.6 Notes on Use of Manual

---

### 1.6.1 Notes on the Manual Structure

This manual is structured in functional and task orientated chapters.

### 1.6.2 Notes and their Illustrations used in the Chapters

<b>DANGER</b>	<b>Brief description of danger</b>
	<p>There is an imminent danger to life and limb of the user and / or third parties when the instructions are not followed precisely or the circumstances described are not taken into account.</p> <p>The type of danger is indicated by a symbol and explained in the accompanying text in more detail. The general symbol for danger is used in this example.</p>
<b>WARNING</b>	<b>Brief description of danger</b>
	<p>There is an indirect danger to life and limb of the user and / or third parties when the instructions are not followed precisely or the circumstances described are not taken into account.</p> <p>The type of danger is indicated by a symbol and explained in the accompanying text in more detail. The general symbol for danger is used in this example.</p>
<b>ATTENTION</b>	<b>Brief description of danger</b>
	<p>There is a potential risk of injury or damage to property when the instructions are not followed precisely or the circumstances described are not taken into account.</p> <p>The type of danger is indicated by a general symbol and explained in the accompanying text in more detail. The general symbol for danger is used in this example.</p>
<b>NOTE</b>	<b>Brief description of additional information</b>
	<p>Attention is pointed to special conditions or additional important information on the respective subject.</p>
<b>INFO</b>	<b>Short title</b>
	<p>Contains additional information on work assisting features or recommendations on the respective subject.</p>



## 2 Safety Instructions

---

### 2.1 Introduction

---

The chapter on safety instructions describes the risks associated with the appliance in terms of product liability (according to the EU Directives).

The safety instructions should warn of hazards and help to avoid damages to persons, the environment and property. Please make sure that you have read and understood all the safety instructions given in this chapter.

You must comply with the respectively valid national and international Safety at Work Regulations. The manager is responsible for the valid regulations he/she has to provide. He/she must acquaint himself/herself and the operator with the new regulations.

In addition to these operating instructions, comply with the rules on health and safety at work issued by the Main Association of the industrial Professional Associations, especially with those that concern the handling of hot items and risks involved (BGR 110 "Protection of health and safety at work in restaurants" and BGR 111 "Protection of health and safety at work in large-scale kitchens").

### 2.2 Warning Symbols Used

---

Symbols are used in these operating instructions to point out the dangers that can occur while operating or cleaning the appliance. In both cases, the symbol provides information on the type and circumstances of danger.

The following symbols can be used:



General hazardous area



Risk of hand injuries

---

### 2.3 Safety Instructions for Appliance Safety

---

Safe operation of the appliance depends on appropriate and thorough use. Negligent handling of the appliance can lead to danger to life and limb of the user and / or third parties as well as hazards to the appliance itself and the other operator's property.

The following points are to be observed to ensure the appliance safety:

- The appliance may only be operated when it is in perfect condition with regards to technical standards.
- All the operating and actuating elements must be in a perfect and functionally reliable condition with regards to technical standards.
- Modifications or retrofits of the equipment are only permitted in consultation with the manufacturer and on receipt of his written agreement.
- In no case may people sit or stand on the appliance. Transport of persons is not permitted.
- Before loading, the tray dispensing height at closed tray dispensers needs to be adjusted to the trays used.
- Never push the stacking platform down manually (e.g. for cleaning). There is a risk of injury when released.

### 2.3.1 Special safety instructions for mobile tray dispensers

- The appliance is provided exclusively for manual transport. Transport using any kind of devices is not permitted. Risk of injury and damage.
- Release both total brakes before commencing transporting. Moving the appliance with the total brakes locked can damage the chassis.
- Transport should only be undertaken over level floors. Moving the appliance over very uneven floors can damage the chassis.
- Transport over inclined planes or steps is not permitted.
- When approaching walls and moving round obstacles always pay attention to persons in the way. Risk of injury.
- When transporting the appliance, always hold both handles with your hands. Never let go of the appliance while moving it.
- When transporting the appliance, do not move it faster than a walking pace. Heavily laden tray dispensers are difficult to brake and steer. If necessary, ask for assistance when transporting the appliance.
- If the tray dispenser tips over due to outside influences or inattention, never catch it manually. Risk of injury.
- Do not stop the appliance on sloping floors.
- After stopping, the appliance should be secured against rolling away by means of both total brakes being applied.
- In the case of off-site transport in a vehicle such as a lorry, the appliances should be secured properly. The total brakes are not sufficient as a transport securing method.

### 2.3.2 Special safety instructions for open tray dispensers

- The stacking platforms of the models OTA/47-36 and OTA/53-37 are not adjustable. Only suitable tray sizes may be transported.
- It is necessary to ensure that the stacking area of the models OTA/53-37 S and OTA/U-BW is always adjusted to the dimensions of the trays to be transported.
- The trays always have to be laid up within the edge on the stacking platform.
- No items may be placed on the base plate when transporting.
- The paths of the outrigger may not be blocked.

### 2.3.3 Special safety instructions for closed tray dispensers

- To avoid injuries to the hands, care should always be taken to ensure that the dispensing height does not fall below the upper rim of the housing.

## 2.4 Safety Instructions for Cleaning and Care

---

The following points must be observed when carrying out any cleaning and maintenance operations:

- For reasons of hygiene, the cleaning instructions must be strictly observed.
- Do not clean the appliance with steam-jet or high-pressure washers.

## 2.5 Safety Instructions for Troubleshooting

---

The following points shall be observed when carrying out any maintenance and troubleshooting operations:

- All troubleshooting work should only be carried out by authorised specialists.
- Defective components should only be replaced with original parts.
- The local applicable Accident Prevention Regulations must be observed.

## 3 Description and Technical Data

---

### 3.1 Performance Description

---

Tray dispensers are provided for the transport and storage of different trays in large-scale catering establishments and in the food service industry. If necessary, there are various models available:

Models of the type OTA are preferably used in areas of customer self-service counters, bistros and cafeterias. Furthermore, they can be used for the storage of trays on food distribution belts and in sculleries if there is no automatic stacking.

Models of the type OTA/S are suitable for the stacking of trays at crockery return conveyors, also in connection with a stacking device. The trays are placed in the longitudinal direction and are held in place by the sideways tray guide rails. The stacking area is adjustable in length and width to different tray dimensions.

Open basket dispensers of the type OTA/U-BW are suitable for the automatic stacking of trays in longitudinal or transverse direction at dishwashers. The stacking area is adjustable in length and width to different tray dimensions.

Models of the type OTA-E/BA-4xGN are also used in areas of customer self-service bars, bistros and cafeterias. They do not only provide trays but also cutlery in GN containers with sneeze guard.

Models of type TAG are closed tray dispensers for a stack of EN or GN trays. They are preferably used as a tray dispenser in the guest area of cafeterias, canteens, rest houses and bistros used. In contrast to open tray dispensers, the tray column is guided on all sides above the entire height and can not be overturned. Due to the closed side walls, the tray dispenser can store trays of different colours and formats without disturbing the overall visual impression.

Models of the type TA are closed on the front side and are intended for two stacks of EN trays and GN trays. Due to the high capacity, these models are ideal for the use on food distribution belts.

Besides the mobile tray dispensers, there is the model EBS-T intended for installation in worktops.

### 3.2 Proper Use

---

Tray dispensers are intended exclusively for transport and storage of trays ready for use.

Appliances of the type TAG have no compartment inner panelling. Therefore, universal trays, breakfast trays and trapeze-shaped trays can not be inserted because of the smaller tray dimensions.

Appliances of the type TA are suitable only for EN and GN trays due to the half-open design. Other tray dimensions may not be used.

Proper use includes observing defined procedures, compliance with the stated specifications and use of supplied or additionally available original accessories.

Any other use of the appliance is considered as unintended use.

### 3.3 Improper Use

---

It is not permitted to load the tray dispenser with other loads as given.

Tray dispensers are not intended to transport food.

In no case may people sit or stand on the appliance. Transport of persons is not permitted.

No liability is assumed and no warranty claims can be submitted for damages caused by improper use.

### 3.4 Appliance Description

#### 3.4.1 View of the appliance

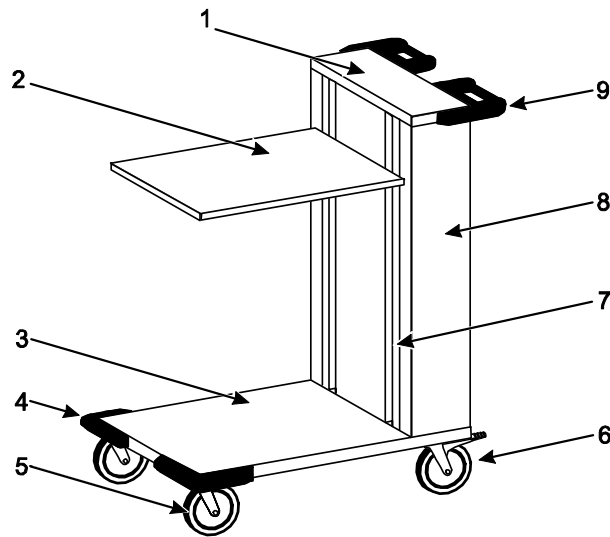

**Figure 1** View of the appliance OTA

- |   |                              |   |                           |
|---|------------------------------|---|---------------------------|
| 1 | Cover of the spring case     | 6 | Casters with total brakes |
| 2 | Stacking platform            | 7 | Paths of the outrigger    |
| 3 | Base plate                   | 8 | Spring case               |
| 4 | Corner bumpers               | 9 | Push bar                  |
| 5 | Casters without total brakes |   |                           |

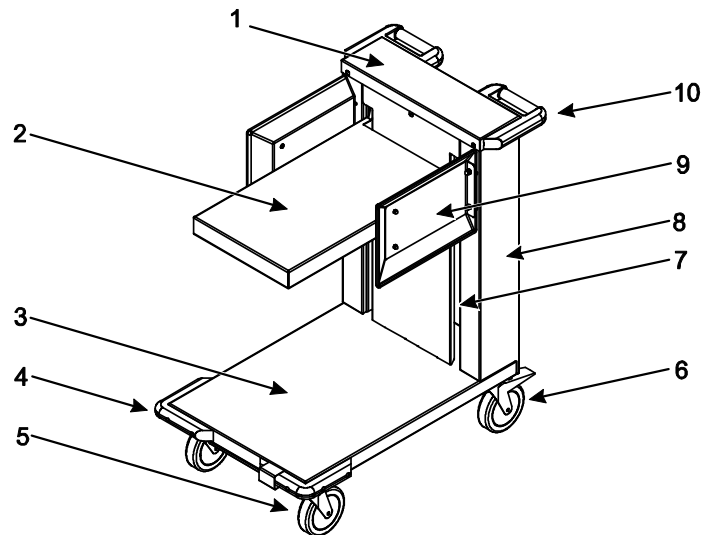

**Figure 2** View of the appliance OTA/S

- |   |                              |    |                           |
|---|------------------------------|----|---------------------------|
| 1 | Cover of the spring case     | 6  | Casters with total brakes |
| 2 | Stacking platform            | 7  | Paths of the outrigger    |
| 3 | Base plate                   | 8  | Spring case               |
| 4 | Corner bumpers               | 9  | Sideways tray guide rail  |
| 5 | Casters without total brakes | 10 | Push bar                  |

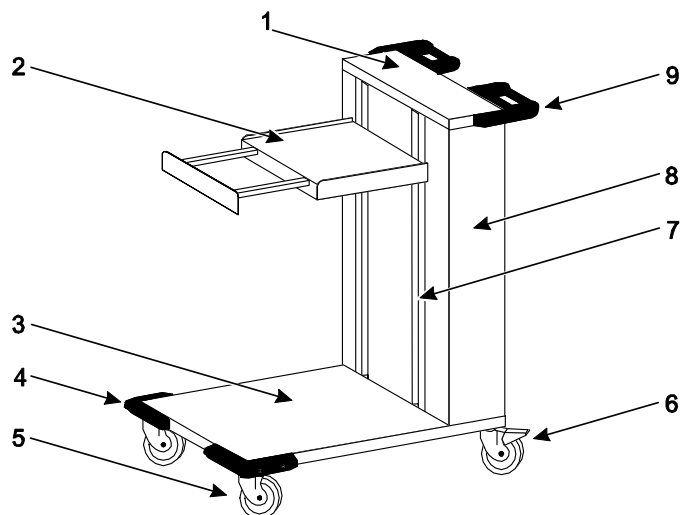

**Figure 3** View of the appliance OTA/U-BW

- |   |                                       |   |  |
|---|---------------------------------------|---|--|
| 1 | Cover of the spring case              | 6 | Casters with total brakes                          |
| 2 | Stacking platform with tray stop unit | 7 | Paths of the outrigger (in the front and sideways) |
| 3 | Base plate                            | 8 | Spring case  |
| 4 | Corner bumpers                        | 9 | Push bar   |
| 5 | Casters without total brakes          |   |  |

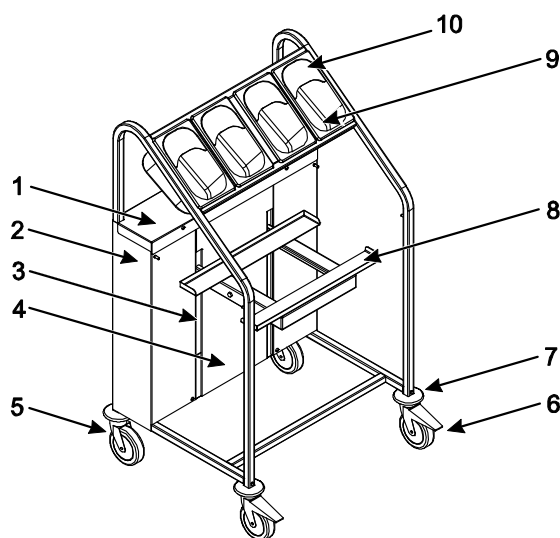

**Figure 4** View of the appliance OTA-E/BA-4xGN

- |   |                              |    |                           |
|---|------------------------------|----|---------------------------|
| 1 | Cover of the spring case     | 6  | Casters with total brakes |
| 2 | Spring case                  | 7  | Protection plate          |
| 3 | Paths of the outrigger       | 8  | Stacking platform         |
| 4 | Panel for the spring case    | 9  | Cutlery holder            |
| 5 | Casters without total brakes | 10 | Sneeze guard              |

### 3.4.2 Appliance Description

Tray dispensers are executed in the self-supporting construction of stainless steel. They accommodate trays on a spring-loaded stacking platform. Owing to the use of special springs, trays are moved automatically and constantly over the entire lift upwards to a uniform dispensing height.

The ergonomically formed push bars with integrated bumper protect the operating staff against damages to the hands. Corner bumpers on the rear protect the appliance against damages when transporting it.

The stacking platform of the models TA, TAG and EBS-T is removable and makes it possible to adjust the springs as well as to clean the appliance easily.



### 3.4.3 Optional special accessories

The following parts can be applied as optional accessories for the movable tray dispenser:



- Casters made of corrosion-resistant and maintenance-free plastic with a thread guard, a precision ball bearing, Ø 4.9" (125 mm) with and without the total brakes, plate attachment
- Holder for dispensing napkins (for OTA E/BA-4xGN)

The part numbers of the special accessories can be found in the spare parts catalogue and order lists available online.

## 3.5 Technical Data

	Dim.	OTA/47-36	OTA/53-37	OTA/58-33
View of the appliance				
Description		Open tray dispenser	Open tray dispenser	Open tray dispenser
Own weight	lbs (kg)	105.8 (48)	105.8 (48)	105.8 (48)
Payload	lbs (kg)	264.5 (120)	264.5 (120)	264.5 (120)
Permitted total weight	lbs (kg)	370.3 (168)	370.3 (168)	370.3 (168)
Overall dimensions w x d x h	in (mm)	20.27 x 31.49 x 35.43 (515 x 800 x 900)	20.27 x 31.49 x 35.43 (515 x 800 x 900)	20.27 x 31.49 x 35.43 (515 x 800 x 900)
Chassis	in (mm)	4 swivel casters, 2 with total brakes, Ø4.92" (125)	4 swivel casters, 2 with total brakes, Ø4.92" (125)	4 swivel casters, 2 with total brakes, Ø4.92" (125)
Stacking platform	in (mm)	18.9 x 14.57 (480 x 370) Stainless steel	21.25 x 14.96 (540 x 380) Stainless steel	23.03 x 13.18 (585 x 335) Stainless steel
Stack height	in (mm)	25.19 (640)	25.19 (640)	25.19 (640)
possible tray dimensions Length x Width	in (mm)	18.5 x 14.17 (470 x 360)	20.86 x 14.56 (530 x 370)	22.63 x 12.79 (575 x 325)

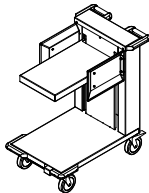
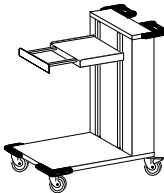
	Dim.	OTA/47-36	OTA/53-37	OTA/58-33
suitable tray types		1 x Universal trays 18.11 x 13.54 (460 x 344)	1 x EN trays 20.86 x 14.56 (530 x 370) 1 x GN trays 22.63 x 12.79 (530 x 325) 1 x Universal trays 18.11 x 13.54 (460 x 344) 1 x Trapeze-shaped trays 18.89 x 13.77 (480 x 350)	1 x EN trays 20.86 x 14.56 (530 x 370) 1 x GN trays 22.63 x 12.79 (530 x 325) 1 x Universal trays 18.11 x 13.54 (460 x 344) 1 x Trapeze-shaped trays 18.89 x 13.77 (480 x 350) 2 x Breakfast trays 12.79 x 8.34 (325 x 212)
Capacity - trays per stack		120	120	120

	Dim.	OTA/53-37 S	OTA/U-BW	OTA E/BA-4xGN
View of the appliance				
Description		open tray dispenser with sideways tray guide rail	open tray dispenser with adjustable stacking platform	open cutlery and tray trolley
Own weight	lbs (kg)	105.82 (48)	110.23 (50)	77.16 (35)
Payload	lbs (kg)	264.55 (120)	264.55 (120)	264.55 (120)
Permitted total weight	lbs (kg)	370.3 (168)	374.78 (170)	341.71 (155)
Overall dimensions w x d x h	in (mm)	20.27 x 31.49 x 35.43 (515 x 800 x 900)	20.27 x 31.49 x 40.35 (515 x 820 x 1025)	31.29 x 26.37 x 50.78 (795 x 670 x 1290)
Chassis	in (mm)	4 swivel casters, 2 with total brakes, Ø4.92" (125)	4 swivel casters, 2 with total brakes, Ø4.92" (125)	4 swivel casters, 2 with total brakes, Ø4.92" (125)
Stacking platform	in (mm)	21.65 x 12.32 (550 x 313) Stainless steel	12.79 x 12.59 (325 x 320) Stainless steel	15.15 x 21.25 (385 x 540) Stainless steel
Stack height	in (mm)	25.19 (640)	22.44 to 30.31 (570 to 770)	23.62 (600)
possible tray dimensions Length x Width	in (mm)	20.9 x 14.56 (530 x 370)	L = 12.99–21.65 (330 – 550) W= 12.59 – 21.25 (320 – 540)	20.86 x 12.79 (530 x 325) 20.86 x 14.56 (530 x 370)
suitable tray types		1 x Universal trays 18.11 x 13.54 (460 x 344) 1 x Trapeze-shaped trays 18.89 x 13.77 (480 x 350) 2 x Breakfast trays 12.79 x 8.34 (325 x 212)	1 x EN trays 20.86 x 14.56 (530 x 370) 1 x GN trays 22.63 x 12.79 (530 x 325) 1 x Universal trays 18.11 x 13.54 (460 x 344) 1 x Trapeze-shaped trays 18.89 x 13.77 (480 x 350)	1 x EN trays 20.86 x 14.56 (530 x 370) 1 x GN trays 22.63 x 12.79 (530 x 325)
Capacity - trays per stack		120	80 to 120	100
suitable GN containers		-	-	4 x GN ¼-150
Capacity Cutlery holder		-	-	4 x 100 cutlery items

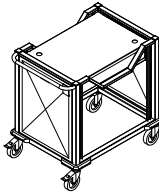
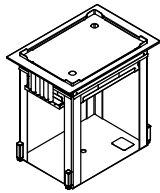
	Dim.	TAG-1/53-37	TA-2/53-37	EBS-T/53-37
View of the appliance				
Description		closed tray dispenser	half-open tray dispenser	Tray dispenser for installation from above
Own weight	lbs (kg)	108.02 (49)	105.82 (48)	39.68 (18)
Payload	lbs (kg)	264.55 (120)	529.04 (240)	220.46 (100)
Permitted total weight	lbs (kg)	372.57 (169)	634.92 (288)	260.14 (118)
Overall dimensions w x d x h	in (mm)	20 x 32.4 x 35.43 (510 x 822x 900)	26.96 x 37.91x 35.43 (685 x 963 x 900)	25.98 x 18.11 x 25.78 (660 x 460 x 655)
Worktop cutout	in (mm)	-	-	24.80 x 16.92 (630 x 430)
Chassis	in (mm)	4 swivel casters, 2 with total brakes, Ø4.92" (125)	4 swivel casters, 2 with total brakes, Ø4.92" (125)	-
Stacking platform	in (mm)	21.49 x 15.19 (546 x 386) Stainless steel	30.31 x 21:22 (770 x 539) Stainless steel	21.02 x 14:72 (534 x 374) Stainless steel
Stack height	in (mm)	22.44 (570)	22.44 (570)	19.29 (490)
suitable tray types		1 x EN trays 20.86 x 14.56 (530 x 370) 1 x GN trays 22.63 x 12.79 (530 x 325)	2 x EN trays 20.86 x 14.56 (530 x 370) 2 x GN trays 22.63 x 12.79 (530 x 325)	1 x EN trays 20.86 x 14.56 (530 x 370) 1 x GN trays 22.63 x 12.79 (530 x 325)
Capacity - trays per stack		120	120	up to 100

The corresponding test marks can be found on our home page at [www.hupfer.de](http://www.hupfer.de).



### 3.6 Rating Plate

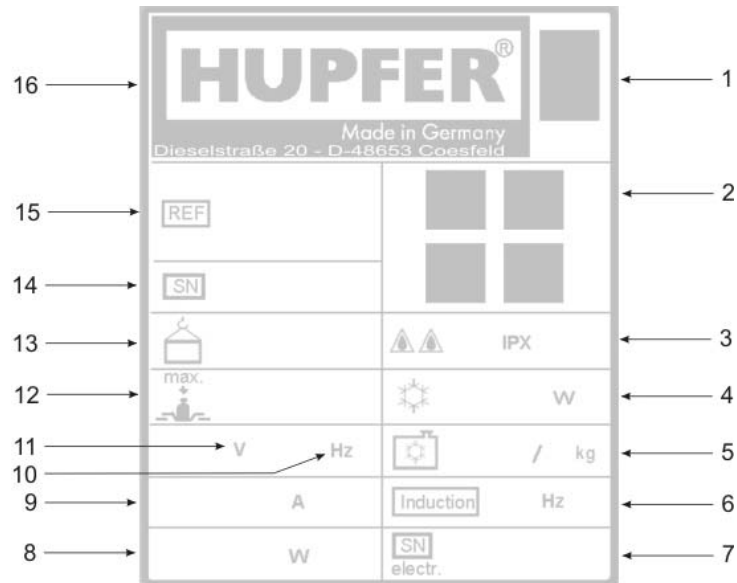

**Figure 5** Rating plate

1	Disposal of old appliances	9	Nominal current
2	Certificates/label	10	Frequency
3	Protection class	11	Nominal voltage
4	Chilling capacity	12	Payload
5	Refrigerant	13	Own weight
6	Induction frequency	14	Serial number/Order number
7	Current serial number	15	Item and brief description
8	Electric power	16	Manufacturer

## 4 Transport, Commissioning, Assembly and Decommissioning

### 4.1 Transport

#### ATTENTION

#### Damages caused by improper transport



In the case of off-site transport in a vehicle such as a lorry, the appliances should be secured properly. The total brakes are not sufficient as a transport securing method.

If the appliances are not secured properly, there is a risk of damage to property and persons caused by squashing.

During transport, secure all the individually standing appliances using corresponding transport securing devices.

#### ATTENTION

#### Exposed springs



When pressing down the stacking platform manually, the springs are exposed. Reaching into the gaps of the exposed springs may cause hand injuries.

Never press the stacking platform down manually.

Be careful when hooking and unhooking the springs. When adjusting springs on sharp edges, pay particular attention to the ends of the tension springs.

### 4.2 Assembly (EBS-T/53-37 only)

The following section describes the assembly of the built-in appliance.

#### NOTE

#### Appliance location

Built-in appliances may only be used after being retrofitted or built-in (e.g. in a cabinet).

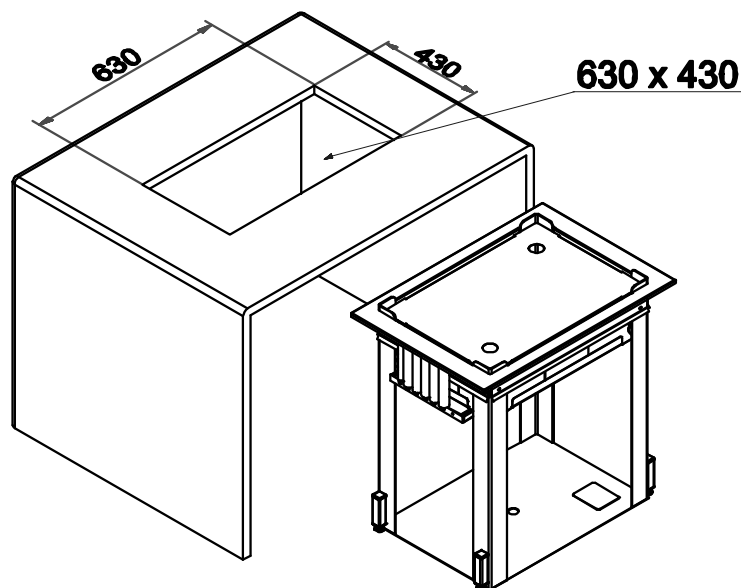

Figure 6

Worktop cut-out EBS-T/53-37

### Step 1: Preparation

- Prepare cut-outs in the worktop corresponding to the indicated dimensions. The worktop cut-out dimensions are given in mm as shown in the drawing.
- Remove the protective plastic film from the metal plates.

### Step 2: Installation



Abbildung 7 Assembly instructions EBS-T/53-37

- Insert the appliance precisely into the worktop cut-out from above and fasten it.
- If necessary, adjust the screw feet.
- Put on the cladding.

## 4.3 Putting into Operation

Before the first use of the appliance, remove the protective plastic film from the metal plates.

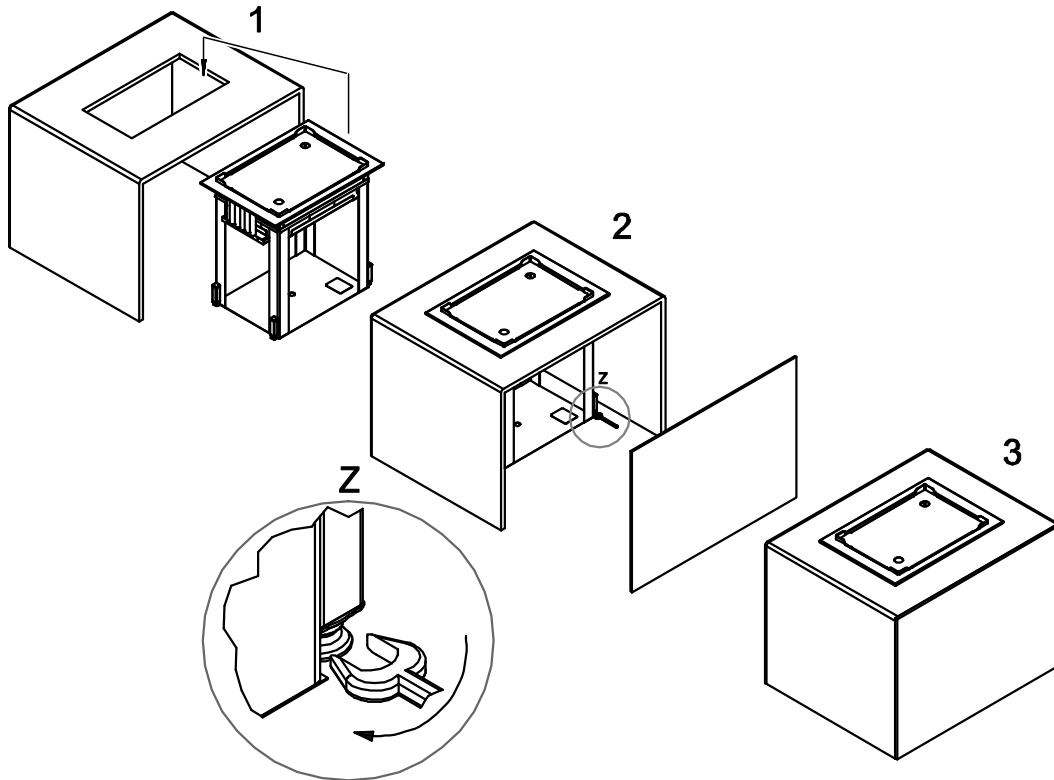
### INFO

### Disposal of packing material

The packing consists of recyclable materials and can be disposed of appropriately. Thereby, the different materials are to be separated and disposed in an environmentally compatible manner. In any case, the local bodies responsible for disposal are to be involved for this purpose

Before putting the appliance into operation, it is necessary to check whether the appliance functions properly.

The following functions are to be checked separately:

- In the mobile appliances: Function of the total brakes.

Ensure the appliance is clean and dry before it is put into operation.

## 4.4 Storage and Recycling

---

Temporary storage must take place in a dry and frost-free environment. The tray dispenser must be kept covered with a suitable covering material to be protected against dust ingress.

The tray dispenser kept in the storage location must be checked for damages and corrosion every 6 months.

<b>NOTE</b>	<b>Condensed water formation</b>
Ensure that there is sufficient ventilation and no large temperature fluctuations in the storage location to avoid condensed water formation.	

Before the appliance is taken back into operation, it must be clean and dry.

If the tray dispenser is required to be recycled, all the heating devices (if available) must be removed safely and completely, the recyclable materials must be separated properly and disposed in an environmentally compatible manner according to the Waste Disposal Regulations. In any case, the local bodies responsible for disposal are to be involved for this purpose.

## 5 Operation

### 5.1 Adjustment of the closed Tray Dispensers

#### 5.1.1 Adjusting springs

##### ATTENTION

##### Damage to persons and property due to improper adjustment



When the dispensing height is exceeded, there is a risk of accident or injury due to tipping of the tray stack. If the level falls below the dispensing height at closed tray dispensers, injuries to the fingers due to squashing can occur when removing dishes.

Be careful when taking the stacking platform out and putting it back in. If it is handled incorrectly, there is a risk of crushing your fingers.

Adjust appropriately the dispensing height by hooking or unhooking the springs. When adjusting springs on sharp edges, pay particular attention to the ends of the tension springs.

##### ATTENTION

##### Exposed springs



When pressing down the stacking platform manually, the springs are exposed. Reaching into the gaps of the exposed springs may cause hand injuries.

Never press the stacking platform down manually.

Be careful when hooking and unhooking the springs. When adjusting springs on sharp edges, pay particular attention to the ends of the tension springs.

Before loading, the crockery dispensing height must be adjusted to the trays used. The dispensing height is adjusted by hooking or unhooking tension springs. So long as the same kind of trays is always used, the dispensing height only needs to be set once.

The springs must be adjusted so that the rim of the uppermost tray remains at a uniform dispensing height between 1.38 and 1.97 " (35 and 50 mm) above the upper rim of the housing over the entire lift

#### Step 1: Checking the spring adjustment

- Load a stack of 15 to 20 trays on to the stacking platform to test the dispensing height.
- Wait for a reaction.

If the edge of the uppermost tray is between 35 mm (1.38") and 50 mm (1.97") above the upper edge of the housing, the spring system is adjusted correctly.

If the stacking platform drops down only a little or not at all, the dispensing height must be altered by adjusting the springs.

#### Step 2: Changing the spring adjustment

The dispensing height is adjusted or changed by hooking or unhooking tension springs on the two opposite attachment bars.

The springs in the model TAG are arranged in groups of 6, where 5 are base springs with higher tension (1) and 1 is an adjustable spring (2) with lower tension.

The springs in the model TA are arranged in groups of 11, where 10 are base springs with higher tension (1) and 1 is an adjustable spring (2) with lower tension.

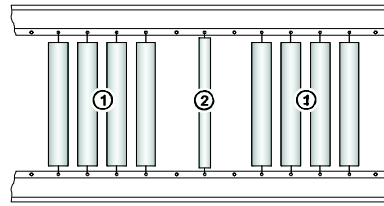

**Figure 8** Attachment bar with tension springs (example)

If the dispensing height is too high, adjustable springs must be unhooked.

If the dispensing height is too low, adjustable springs must be added.

**Procedure for setting the springs:**

- Take out the inserted crockery items (if available).
- Lift the stacking platform uniformly with the grip holes and put it down in a suitable place.
- Hook or unhook adjustable springs uniformly in all groups of springs.
- Preferably unhook the adjustable springs. Always leave the base springs inserted, if possible. Always unhook the springs on the lower attachment bar.
- Then reinsert the stacking platform using the grip holes. If the stacking platform is inserted correctly, the guide rollers must face the interior of the appliance. Otherwise the crockery can become dirty.
- 

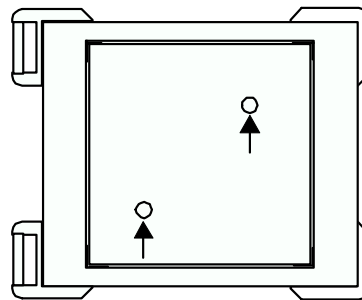

**Figure 9** Grip holes on the stacking platform

<b>NOTE</b>	<p><b>Arrangement of the springs</b></p> <p>A symmetrical arrangement of springs between the attachment bars is necessary for guiding the stacking platform uniformly and without friction. A slightly asymmetrical arrangement of springs within an attachment bar does not pose any problem.</p>
<b>NOTE</b>	<p><b>Maximum load-bearing capacity</b></p> <p>Since all the tray dispensers are designed for a maximum load, the available spring system of the appliances is entirely sufficient for all usual market crockery items. If the existing spring sets are insufficient, additional springs must be added.</p>

## 5.2 Adjustment of the open Tray Dispensers

### 5.2.1 Adjust the model OTA/S

INFO	Required tools
	You need the following tools for the adjustment: Open-end wrench SW 17, Philipps screwdriver size 1, Screwdriver size 7 (chisel width 6-7 mm) and thickness 0.8–1 mm)

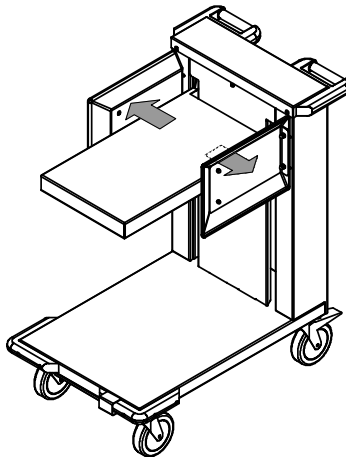

**Figure 10** Adjust tray guide rails

#### Adjust the sideways tray guide rails

The holders of both tray guiding rails have to be fixed with two cap nuts on the left and right sides on the spring case. The sideways tray guide rails are adjusted correctly when after the adjustment the trays are located centrally on the stacking platform and sideways have a distance of 0.19" (5 mm) to the tray guide rails.

To adjust the sideways tray guide rail, proceed as follows:

- Loosen all four cap nuts, but do not unscrew them completely.
- Bring the two tray guiding rails evenly in the right position and align them vertically.
- Screw the four cap nuts of the tray guiding rails tight.

## 5.2.2 Adjustments OTA/U-BW

INFO	Required tools
	<p>You need the following tools for changing the stop edge of the cover of the spring case:</p> <p>Open-end wrench SW 17,                      Philipps screwdriver size 1,                      Screwdriver size 7 (chisel width 6-7 mm and thickness 0.8–1.0 mm)                      hexagon wrench SW 5 and 8 mm,                      knife</p>

### Adjusting the stop edges

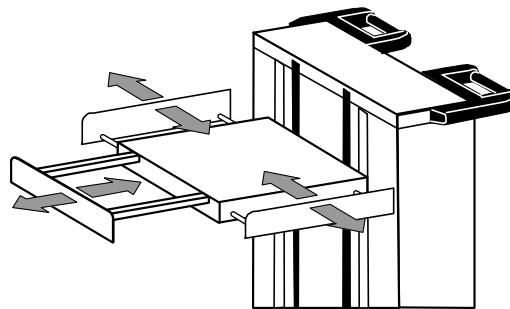

**Figure 11** Adjust stop edges

The stop edges are adjusted correctly when after the adjustment the trays are located centrally on the stacking platform and sideways have a distance of 0.19" (5 mm) to the stop edges. The trays rest directly against the vertical plastic stop beads and are flush at the front edge of the platform.

The adjustment mechanism for the stop edges is located below the stacking platform.

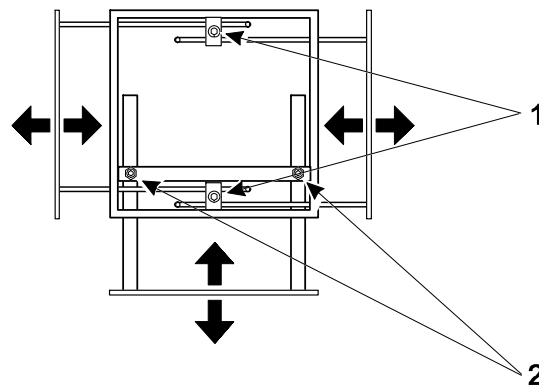

**Figure12** Stacking platform (bottom view)

To adjust the sideways stop edges, proceed as follows:

- Carefully tilt the device so that it rests on the push bars.
- Loosen both cylinder head screws with internal hexagon (1), but do not remove them completely. Therefore use a hexagon wrench SW 8 mm.
- Adjust the lateral stop edges to the desired level.
- Screw the socket head screw tight.

To adjust the front stop edge, proceed as follows:

- Unscrew the two counter nuts (2) from the setscrews. Therefore use an open-end wrench SW 17
- Loosen the setscrews, but do not remove them completely. Therefore use a hexagon wrench 0.19" (5 mm).
- Pull out the front stop to the desired length.



- Tighten the setscrews and secure with the counter nuts.
- Set up the appliance again, so that it stands on all four wheels.

### Adjusting the upper attaching point

To adjust the height of the dishwasher, the upper attaching point of the stacking platform can be set continuously between 27.5 and 19.6" (700 and 500 mm).

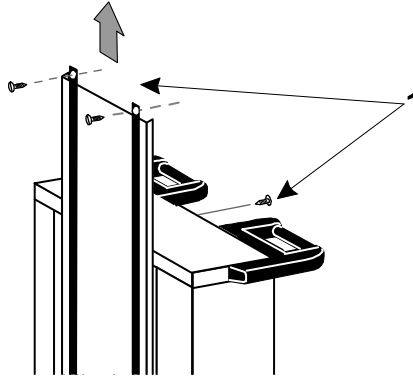

**Figure 13** Adjust stop point

To adjust the upper attaching point, proceed as follows:

- Remove the three screws (1) on the front and back of the cover of the spring case.
- Pull out the frontal sheet with plastic stop beads.
- Remove the cover of the spring case. The push bars remain on the cover of the spring case.

The height of the upper attaching point or the upper spring suspension is adjusted with two threaded rods according to the spindle principle.

Turns to the right shift the attaching point downwards, turns to the left shift the attaching point upwards.

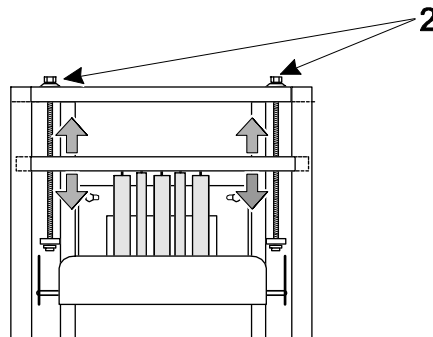

**Figure 14** Heads of the threaded rods

- Turn both heads of the threaded rods (2) until the desired position of the upper stop is reached. Therefore use an open-end wrench SW 17.

NOTE	Uniform rotation
	Pay attention to uniform rotations, as the chassis of the stacking platform can get twisted.

- Put on the cover of the spring case.
- Put the frontal sheet into the embedded folding of the sheet.
- Insert the screws and tighten the cover of the spring case.

### Adjust the position of the spring case

The spring case can be adjusted continuously up to 8.66" (220 mm) to the front.

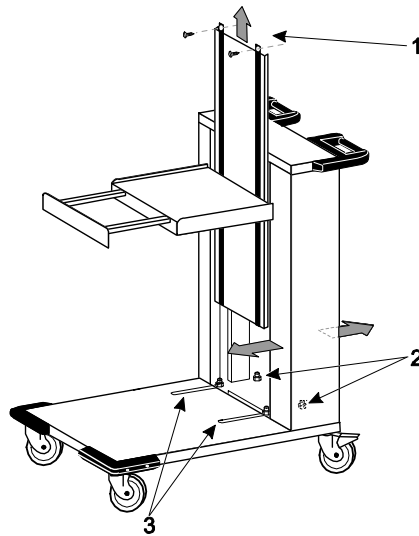

**Figure15** Adjust the spring case

- Remove the screws (1) and pull out the frontal sheet with plastic stop beads.
- Carefully loosen both plastic stop beads (3) in the base plate with a knife or a screwdriver and set it aside. Later they need to be shortened according to the new position of the case spring.
- Loosen the four nuts (2) that connect the spring case with the base plate, but do not remove them completely. Therefore use an open-end wrench SW 17.
- Pull the spring case until the desired position is reached.
- Screw the nuts back into place.
- Shorten the plastic stop beads (3) at the blunt ends and insert into the grooves in the base plate.
- Put the frontal sheet into the folding of the sheet on the the ground and fix it with screws (1) on the spring case.

### 5.2.3 Adjusting springs

Since the tray dispensers are designed for a maximum load, the available spring system of the appliances is entirely sufficient for all purposes.

Before loading, the crockery dispensing height must be adjusted to the trays used. The dispensing height is adjusted by hooking or unhooking tension springs. So long as the same kind of trays is always used, the dispensing height only needs to be set once.

When using open tray dispensers, it is permitted to stack over up to 1.97" (50 mm). This maximum protrusion of the tray dispenser above the upper edge of the spring case may not be exceeded.

#### ATTENTION

#### Damage to persons and property due to improper adjustment



When the dispensing height is exceeded, there is a risk of accident or injury due to tipping of the tray stack. Be careful when taking the stacking platform out and putting it back in. If it is handled incorrectly, there is a risk of crushing your fingers.

Adjust appropriately the dispensing height by hooking or unhooking the springs. When adjusting springs on sharp edges, pay particular attention to the ends of the tension springs.

**ATTENTION**

**Exposed springs**



When pressing down the stacking platform manually, the springs are exposed. Reaching into the gaps of the exposed springs may cause hand injuries.

Never press the stacking platform down manually.

Be careful when hooking and unhooking the springs. When adjusting springs on sharp edges, pay particular attention to the ends of the tension springs.

**Step 1 - Checking the spring adjustment**

- To test the dispensing height, put a stack of 20 trays (OTA) or 3 trays (OTA-S or OTA/U-BW) on the stacking platform.
- Wait for a reaction.

**OTA:** If the edge of the uppermost tray is between 1.38" (35 mm) and 1.97" (50 mm) above the upper edge of the housing, the spring system is adjusted correctly.

**OTA-S:** The tray dispenser is set correctly when the stacking platform lowers when there are 3 trays on it. The upper edge of the uppermost tray must be below the stacking device of the conveyor belt.

**OTA/U-BW:** The tray dispenser is set correctly when the stacking platform lowers when there are 3 trays on it. The upper edge of the uppermost tray must be below the stacking device of the dishwasher.

If the stacking platform drops down only a little or not at all, the dispensing height must be altered by adjusting the springs.

If the dispensing height is too high, adjustable springs must be unhooked.

If the dispensing height is too low, adjustable springs must be added.

**Step 2 - Changing the spring adjustment**

The dispensing height is adjusted or changed by hooking or unhooking the tension springs on two attachment bars within the spring case. For an optimum setting of the spring system, changes at the spring groups is usually sufficient. If the rear springs need to be hooked or unhooked, the cover of the spring case (OTA, OTA and OTA-S / U BW) has to be removed.

The springs are arranged in groups of 5: On the front of the attachment bar there are 4 base springs with higher tension (1) and an adjustable spring with lower tension (2), on the rear attachment bar there are 5 base springs with higher tension(1).

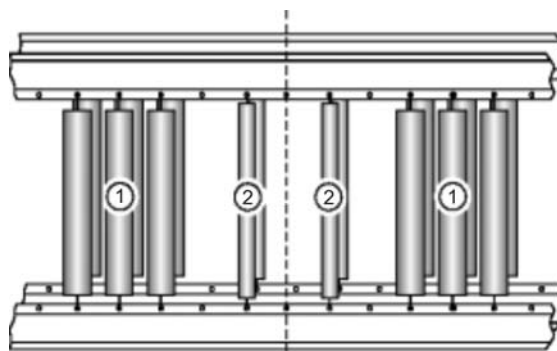

**Figure 16** Attachment bar with tension springs (example)

**NOTE**

**Arrangement of the springs**

The arrangement of the springs must be symmetrical on the left and right within the attachment bar, so that it is ensured, that the stacking platform is guided uniformly and without friction.

**Procedure for setting the springs:**

- Take out the inserted trays (if available).
- Screw the spring case.
- Hook or unhook adjustable springs uniformly in all groups of springs. Preferably unhook the adjustable springs. Always leave the base springs inserted, if possible. Always unhook the springs on the lower attachment bar.

Both steps must be repeated as often as possible, until the dispensing height is in the range from 0.06" (1.5 cm) to 0.1" (2.5 cm). So long as the same kind of crockery is always used, the dispensing height only needs to be set once.

### 5.3 Calculating the Capacity for Tray Dispensers

The capacity of a tray dispenser depends on the trays loaded and the number of stacks. All the leading manufacturers give the necessary data for calculating the intermediate stack height in the following manner:

$$H_z = \frac{(H_n - H_1)}{n-1}$$

$H_z$ : Intermediate stack height  
 $H_1$ : Height of the first tray  
 $H_n$ : Height of n trays  
 n: Number of trays

The capacity per tray stack can be calculated together with the stack height  $H_s$  of the tray dispenser:

$$K = \frac{(H_s - H_1)}{H_z} + 1$$

K: Capacity  
 $H_s$ : Stack height

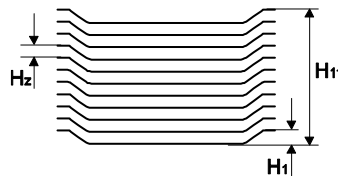

**Figure 17** Intermediate stack height  $H_z$  of 11 trays

Example:

$$H_z = \frac{(140 - 28)}{10} = 11,2 \text{ mm}$$

$H_1 = 28$  :Height of the first tray  
 $H_{11} = 140$  mm: Height of 11 trays  
 $t = 11$ : Number of trays

$$K = \frac{(565 - 28)}{11,2} + 1 = 49 \text{ Teile}$$

$H_s = 24.6"$  (565 mm): Stack height

So 49 trays can be stacked in one position. The capacity doubles on models that are intended for two tray stacks.

## 5.4 Operation

---

### ATTENTION

#### Exposed springs



When pressing down the stacking platform manually, the springs are exposed. Reaching into the gaps of the exposed springs may cause hand injuries.

Never press the stacking platform down manually.

---

Ensure the appliance is clean and dry before it is put into operation.

Before work starts, it is always necessary to check whether the tray dispenser is adjusted correctly for the trays to be used.

The correct dispensing height must be ensured, so that the staff cannot suffer injury or become trapped. Tray dispensers, that are used for washing machines and conveyor systems, must also be adjusted to the dispensing height.

#### Loading the appliance

### NOTE

#### Maximum loading

The maximum filling of the tray dispenser is reached when the tip of the tray stack is about 1.98" (5 cm) above the top edge of the appliance.

---

### NOTE

#### Payload

Make sure that the tray dispenser does not exceed the permitted payload.

---

- Insert the trays in small manageable stacks.

#### Remove trays

- Remove the trays evenly

#### Moving the appliance

- Release both total brakes.
- Grip the appliance by the push bars and move it to the destination.
- At the destination, apply both total brakes in order to secure the appliance against movement.

## 6 Troubleshooting and Repair

### 6.1 Safety Measures

ATTENTION	Exposed springs
	<p>When pressing down the stacking platform manually, the springs are exposed. Reaching into the gaps of the exposed springs may cause hand injuries.</p> <p>Never press the stacking platform down manually.</p> <p>Be careful when hooking and unhooking the springs. When adjusting springs on sharp edges, pay particular attention to the ends of the tension springs.</p>

### 6.2 Notes on Troubleshooting

Service work should only be carried out by authorised specialists. In the event of after-sales service and when ordering spare parts specify the data given in the rating plate.

Only use original spare parts to replace defective components.

Regular inspection and maintenance of the appliance prevent disruptions to operation and ensure safety. Inspection and maintenance intervals depend on the use of the appliance. Consult your dealer's after-sales service department.

### 6.3 Fault and Action Table

Fault	Possible cause	Action
Movable appliances can not keep the track and drag to the left or right  Resistance of the swivel casters is higher than when putting the appliance into operation	Bearings of the swivel caster(s) defective	Exchange defective swivel caster(s)
Total brakes do not have any locking action	Wear of the locking brakes	Replace the locking brakes, replace defective casters
The stacking platform does not go up even when the load is low	Spring breakage	replace the destroyed spring(s)

## 7 Cleaning and Care

---

### 7.1 Safety Measures

---

#### ATTENTION

#### Exposed springs



When pressing down the stacking platform manually, the springs are exposed. Reaching into the gaps of the exposed springs may cause hand injuries.

Never press the stacking platform down manually.

Be careful when hooking and unhooking the springs. When adjusting springs on sharp edges, pay particular attention to the ends of the tension springs.

---

#### ATTENTION

#### Do not clean with running water



The appliance should not be cleaned with running water, steam-jet or high-pressure washers. The appliance must be taken out of operation and switched off at the mains beforehand in any area where steam-jet or high-pressure washers are to be used.

---

### 7.2 Hygiene Measures

---

The correct behaviour of the operating staff is decisive for optimal hygiene.

All persons must be informed about the locally valid hygiene regulations, observe them and comply with them.

Stick a waterproof plaster to cover wounds on the hands and arms.

Never sneeze or cough on clean crockery.

### 7.3 Cleaning and Care

---

The appliance must be cleaned dry daily or wiped with a damp cloth. Dry well the appliance after carrying out wet cleaning, in order to prevent the development of mould, uncontrolled growth of germs and bacteria and, consequently, contamination of the crockery.

The base outlet located under the stacking compartment is installed to remove broken crockery or other objects, which have accidentally fallen down into the appliance.

### 7.4 Special Care Instructions

---

The resistance to corrosion of stainless steels is based on a passive layer which is formed on the surface when oxygen is admitted. The oxygen in the air is sufficient for the formation of the passive layer, so that faults or damage to the passive layer can be remedied again automatically by mechanical action.

The passive layer develops or reforms more quickly when the steel comes into contact with flowing water containing oxygen. The passive layer can be chemically damaged or disrupted by agents having a reducing (oxygen-consuming) action when the steel comes into contact with them in concentrated form or at high temperatures.

Such aggressive substances are for example:

- substances containing salt and sulphur
- chlorides (salts)
- seasoning concentrates (e.g. mustard, vinegar essence, seasoning cubes, saline solutions)

Further damages can occur due to:

- extraneous rust (e.g. from other components, tools or rust film)
- iron particles (e.g. grinding dust)
- contact with non-ferrous metals (element formation)
- lack of oxygen (e.g. no admission of air, low-oxygen water).

General working principles for the handling of appliances made of "refined stainless steel":

- Always keep the surface of appliances made from stainless steel clean and accessible to the air.
- Use cleaning agents suitable for stainless steel. No bleaching and chloride-containing cleaning agents should be used.
- Remove layers of lime scale, grease, starch and egg-white daily by cleaning. Corrosion can occur underneath these layers due to lack of air admission.
- After each cleaning operation remove all cleaning agent residues by rinsing thoroughly with copious fresh water. Afterwards, the surface should be thoroughly dried.
- Do not bring parts made of stainless steel into contact with substances such as concentrated acids, seasonings and salts for longer than is absolutely necessary. Acid fumes which generate during cleaning of tiles also promote the corrosion of "refined stainless steel".
- Avoid damaging the surface of the stainless steel, particularly by metals other than stainless steel.
- Residues of extraneous metals produce extremely small amounts of chemical elements which can cause corrosion. In any case, contact with iron and steel should be avoided because that leads to extraneous rust. If stainless steel comes into contact with iron (steel wool, steel particles from pipes, water containing iron), this can be a trigger for corrosion. Therefore, for mechanical cleaning use exclusively refined steel wool or brushes with natural, plastics or refined steel bristles. Steel wool or brushes with unalloyed steel lead to extraneous rust due to abrasion.



## 8 Spare Parts and Accessories

### 8.1 Introduction

Service work should only be carried out by authorised specialists.

Defective components should only be replaced with original parts.

Always specify the data and corresponding part number indicated on the rating plate when using the after-sales service or ordering spare parts.

### 8.2 Spare Parts and Accessories List

#### OTA

91010963	Push bar	Plastic, left and right	
4040101	Tension spring	Stainless steel 10 gr.	
4055088	Tension spring	Stainless steel 20 gr.	
4002110	Corner bumper	Plastic, black	
04710040A100	Retaining ring	DIN 471 Ø10x1.0	
04710040A150	Retaining ring	DIN 471 Ø15x1.0	
5009500	Deep groove ball bearing	Stainless steel Ø26xØ10x8	
4000401	Swivel caster	Polymer P3/125	
4000402	Swivel caster	Polymer P3/125 with total brake	

#### OTA/E

4002001	Sneeze guard	Luran rauchtöps	
4032006	Cutlery holder	(GN 1/4)	
4055088	Tension spring	Stainless steel 20 gr.	
4040101	Tension spring	Stainless steel 10 gr.	
4002111	Protection plates	Plastic Ø95	
4000406	Swivel caster Plastic	Ø 125	
4000405	Swivel caster Plastic	Ø 125 with total brake	
4124107	Caster	compl.	
4124114	Location bolt	for ball bearing Ø25/50 Ø16.95 12	

#### TAG

4000401	Swivel caster	Polymer P3/125	
4000402	Swivel caster	Polymer P3/125 with total brake	
91010963	Push bar	Plastic, left and right	
4002110	Corner bumper	Plastic, black	
4040101	Tension spring	Stainless steel 10 gr.	
4004104	Tension spring	Stainless steel 20 gr.	
4041030	Guide roller	Ø24	

**TA**

91010963	Push bar	Plastic, left and right	
4040101	Tension spring	Stainless steel 10 gr.	
4004104	Tension spring	Stainless steel 20 gr.	
4000123	Swivel caster	Steel, galvanised, with total brake	
4000122	Swivel caster	Steel, galvanised	
5009500	Bearing	RK stainless steel Ø26/Ø10/8	

## 9 Annex

### 9.1 EC Declaration of Conformity

# CE Konformitätserklärung

Declaration of CE-Conformity | Déclaration de conformité CE



Gegenstand | Object | Objet

Tablettstapler, Korbstapler offen | tray dispenser, basket dispenser open | chariot niveau constant à plateaux, chariot niveau constant à paniers ouvrir

Typ | Type | Type

OTA / TAG / OKO

Es wird bescheinigt, dass das/die zuvor näher beschriebene/n Produkt/e der/den im Folgenden aufgelisteten EU-Richtlinie/n entspricht/entsprechen:

2006/42/EG

Darüber hinaus wurden folgende harmonisierte Normen angewandt:

EN ISO 12100:2010, EN ISO 13857

It is certified that the product/s described in detail before, conform/s to the requirements of the European Union directive/s listed in the following:

2006/42/EC

Furthermore, the following harmonised standards have been applied:

EN ISO 12100:2010, EN ISO 13857

Il est certifié que le/s produit/s décrit/s en détail ci-dessus, correspond/ent aux directive/s de l'UE énuméré/es dans ce qui suit:

2006/42/CE

En outre, les normes harmonisées suivantes ont été appliquées:

EN ISO 12100:2010, EN ISO 13857

Coesfeld, 12.06.2013

Helmut Schumacher  
Vorname, Nachname

Geschäftsführung  
Position

Unterschrift

Jürgen Gottwald  
Vorname, Nachname

Leiter Normenstelle  
Position

Unterschrift

Dokumentationsbevollmächtigter  
Jürgen Gottwald

HUPFER® Metallwerke  
GmbH & Co. KG

info@hupfer.de

Diese Konformitätserklärung ist eine original Konformitätserklärung in deutscher Sprache und kann gleichlautende Übersetzungen in weiteren EU-Sprachen enthalten. This declaration of conformity is an original declaration of conformity in the German language and can contain identical translations in the other EU languages. Cette déclaration de conformité est une déclaration de conformité originale en langue allemande et peut contenir des traductions conformes en d'autres langues de l'UE.

HUPFER® Metallwerke GmbH & Co KG

Dieselstraße 20 | 48653 Coesfeld | Deutschland | +49 2541 805-0 | info@hupfer.de

# CE Konformitätserklärung

Declaration of CE-Conformity | Déclaration de conformité CE

Gegenstand | Object | Objet

Geschirrstapler, Korbstapler, Bohnenst. | crockery dispenser, basket dispenser, platform dispenser | chariot niveau constant à vaisselle, chariot niveau constant à paniers, chariot niveau constant à plateforme

Typ | Type | Type

UST / KO / EBS / BD / BDK / OBK / BPN

Es wird bescheinigt, dass das/die zuvor näher beschriebene/n Produkt/e der/den im Folgenden aufgelisteten EU-Richtlinie/n entspricht/entsprechen:

2006/42/EG

Darüber hinaus wurden folgende harmonisierte Normen angewandt:

EN ISO 12100:2010, EN ISO 13857

It is certified that the product/s described in detail before, conform/s to the requirements of the European Union directive/s listed in the following:

2006/42/EC

Furthermore, the following harmonised standards have been applied:

EN ISO 12100:2010, EN ISO 13857

Il est certifié que le/s produit/s décrit/s en détail ci-dessus, correspond/ent aux directive/s de l'UE énuméré/es dans ce qui suit:

2006/42/CE

En outre, les normes harmonisées suivantes ont été appliquées:

EN ISO 12100:2010, EN ISO 13857

Goesfeld, 12.06.2013

**Helmut Schumacher**  
Vorname, Nachname

**Geschäftsführung**  
Position

Unterschrift

**Jürgen Gottwald**  
Vorname, Nachname

**Leiter Normenstelle**  
Position

Unterschrift

**Dokumentationsbevollmächtigter**  
Jürgen Gottwald

**HUPFER® Metallwerke**  
GmbH & Co. KG

info@hupfer.de

Diese Konformitätserklärung ist eine original Konformitätserklärung in deutscher Sprache und kann gleichlautende Übersetzungen in weiteren EU-Sprachen enthalten. This declaration of conformity is an original declaration of conformity in the German language and can contain identical translations in the other EU languages. Cette déclaration de conformité est une déclaration de conformité originale en langue allemande et peut contenir des traductions conformes en d'autres langues de l'UE.

HUPFER® Metallwerke GmbH & Co KG  
Dieselstraße 20 | 48653 Goesfeld | Deutschland | +49 2541 805-0 | info@hupfer.de

